



# **Puraflo Peat Fiber Biofilter**

## **Quanics Aerocell Recirculating Filter**

## **Quanics BioCoir Recirculating Filter**

### **Install and Maintain**





- The views in this presentation are the presenter's, not representative of NOWRA

# Who we are...

- Our goals
  - Planet preservation (health and environment)
  - Relationships and meaningful collaboration
  - Solutions for handling human impacts
    - Clean Water
    - Clean Air



# Install & Maintain

- Anua or Authorized Representative conducts training for installation & service
  - Classroom training
  - Field training
  - Virtual



# Puraflo System Components Overview



# AeroCell and BioCoir Recirculating Media Filters

## Typical Layout

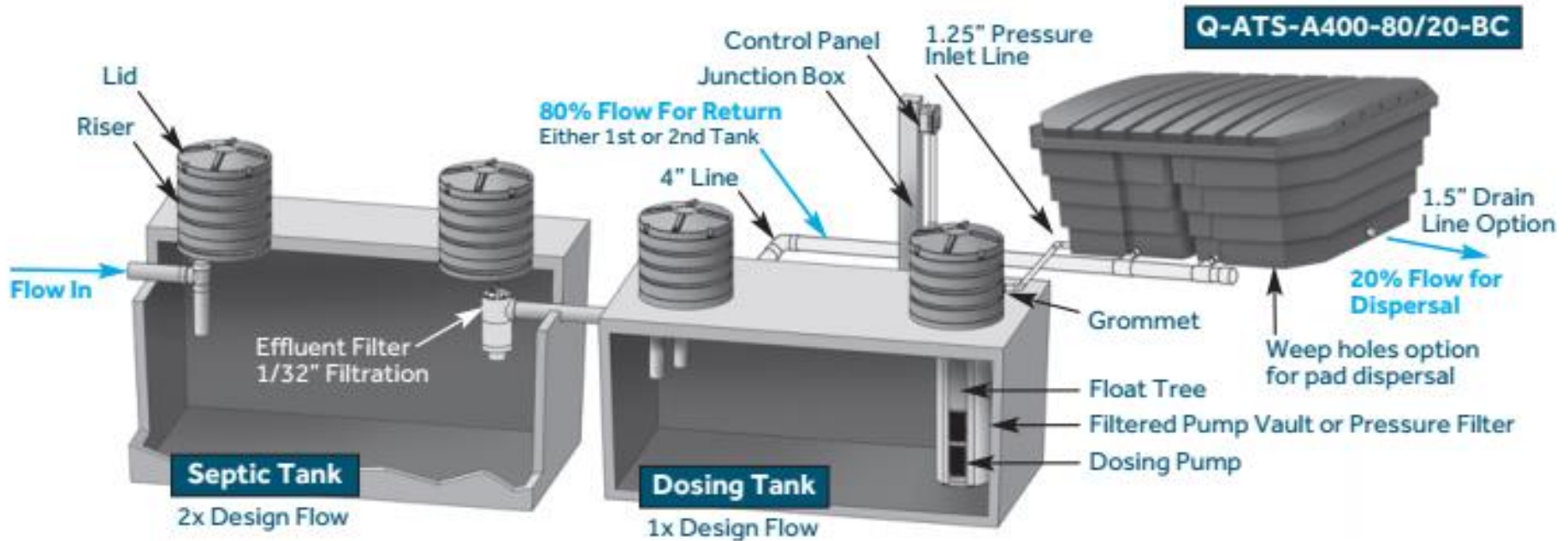

# Maintenance Components

- Effluent filter (1/32" filtration)
- Control Panel
- Pump
- Orifice
- Spray Head
- Media

# Before Performing Maintenance

- Request a set of the Plans from the Health Department
  - What Dose Tank was **specified**
    - Tank Dimensions
  - What pump **specified**
- Request the as-built drawing or inspection notes
  - What Dose Tank was **installed**
    - Tank Dimensions
  - What pump **installed**

# Septic Tank & Effluent Filter

- Septic tank
  - Monitor (Scum, effluent and Sludge layers)
  - Pumping
- Commercial effluent filter
  - 1/32" filtration
  - Clean
  - Inspect

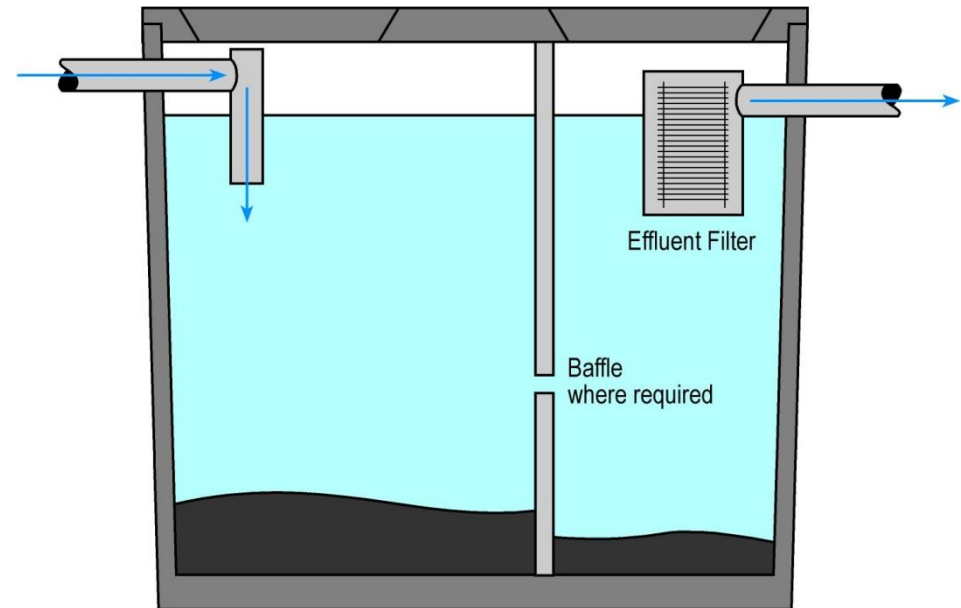

# Timed Dose Pump Tank

- Timed dosed
  - Puraflo
    - Peat -12 doses per day
    - Coir – 72 doses per day
  - Quanics
    - AeroCell - 96 doses per day
    - BioCoir - 96 doses per day



# Timed Dose Pump Tan

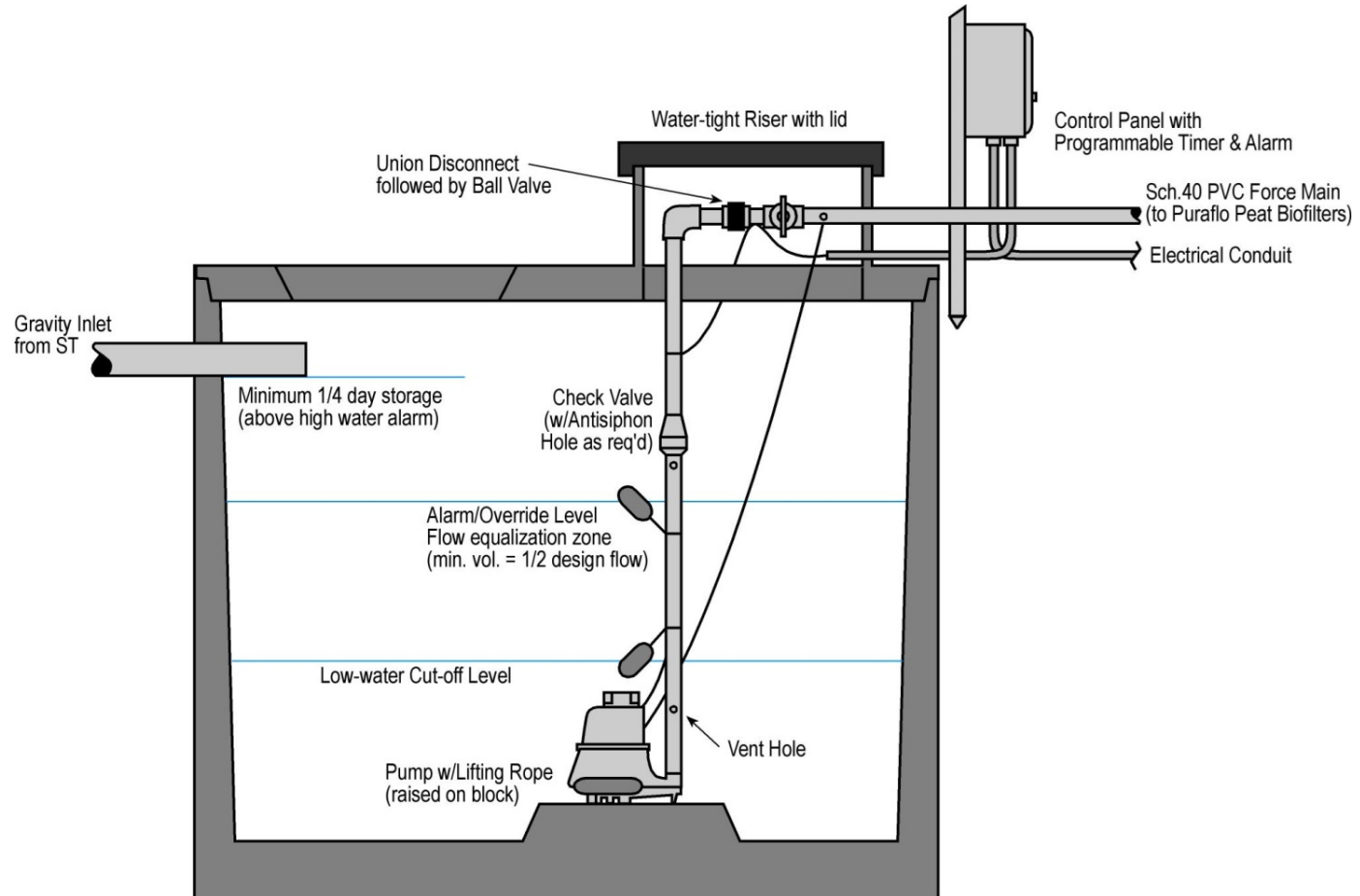

# Timed Dose Pump Tan

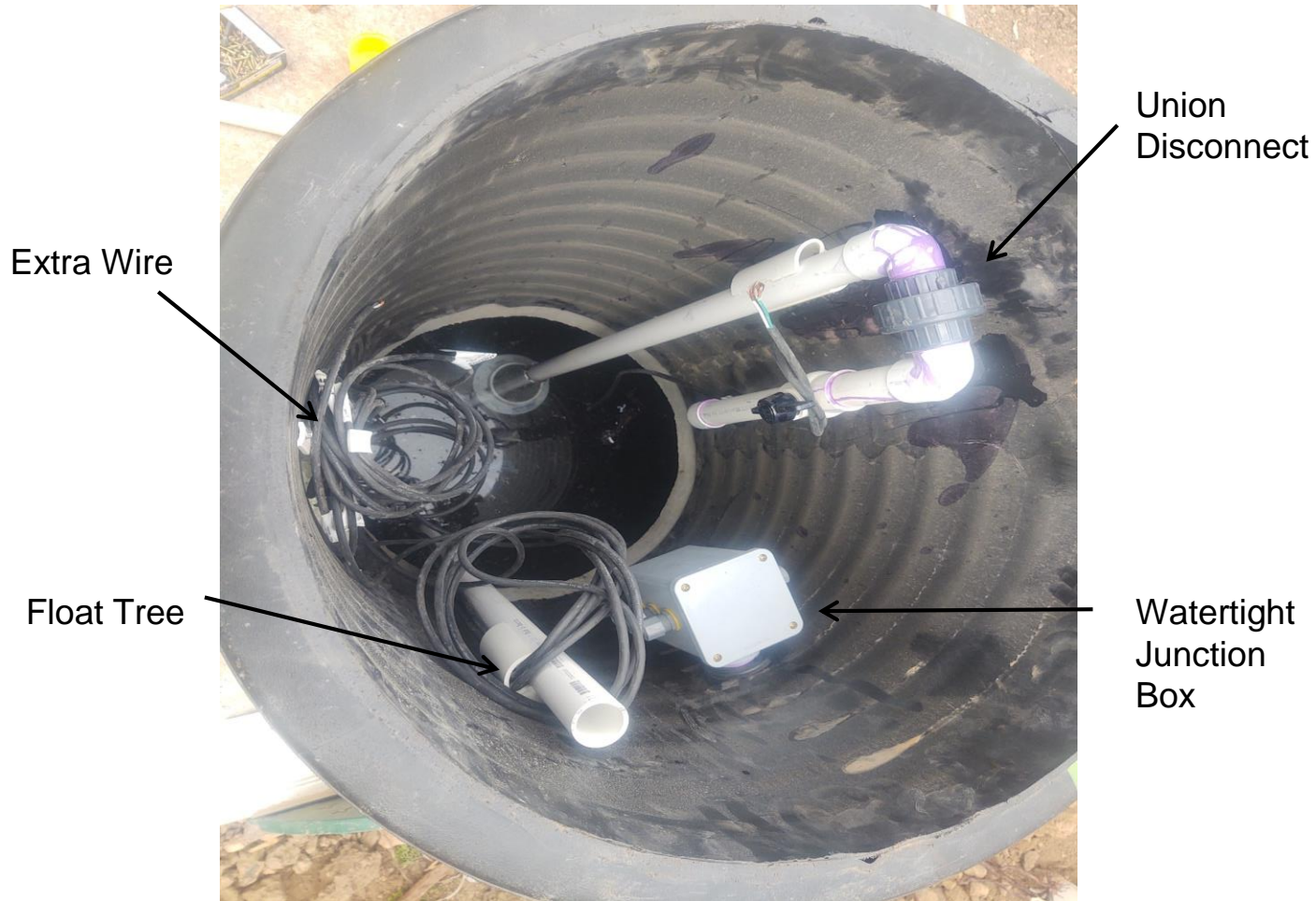

# Timed Dose Pump Tan

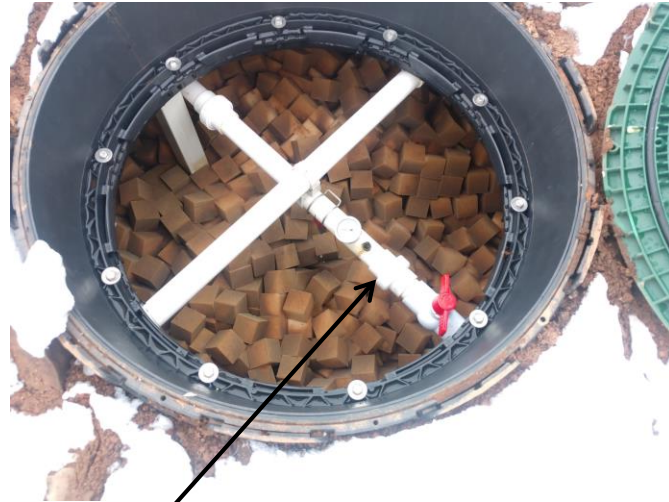

Quick Connection  
with Orifice

# Effluent Distribution

- Helical nozzles spray over 170° cone
- Solid spray pattern not hollow
- 3" clearance above surface soaks 5' dia. cone

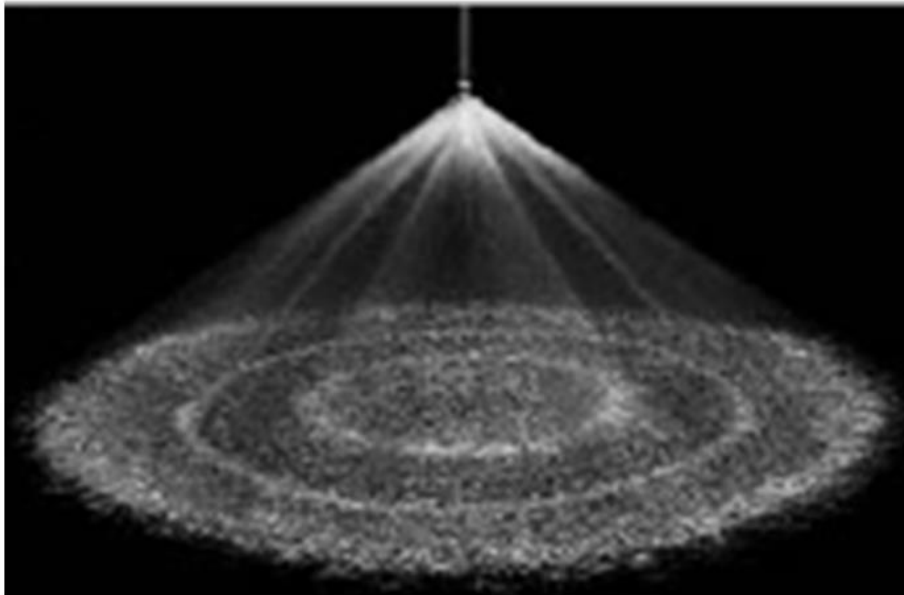

# Start-up & Annual Service

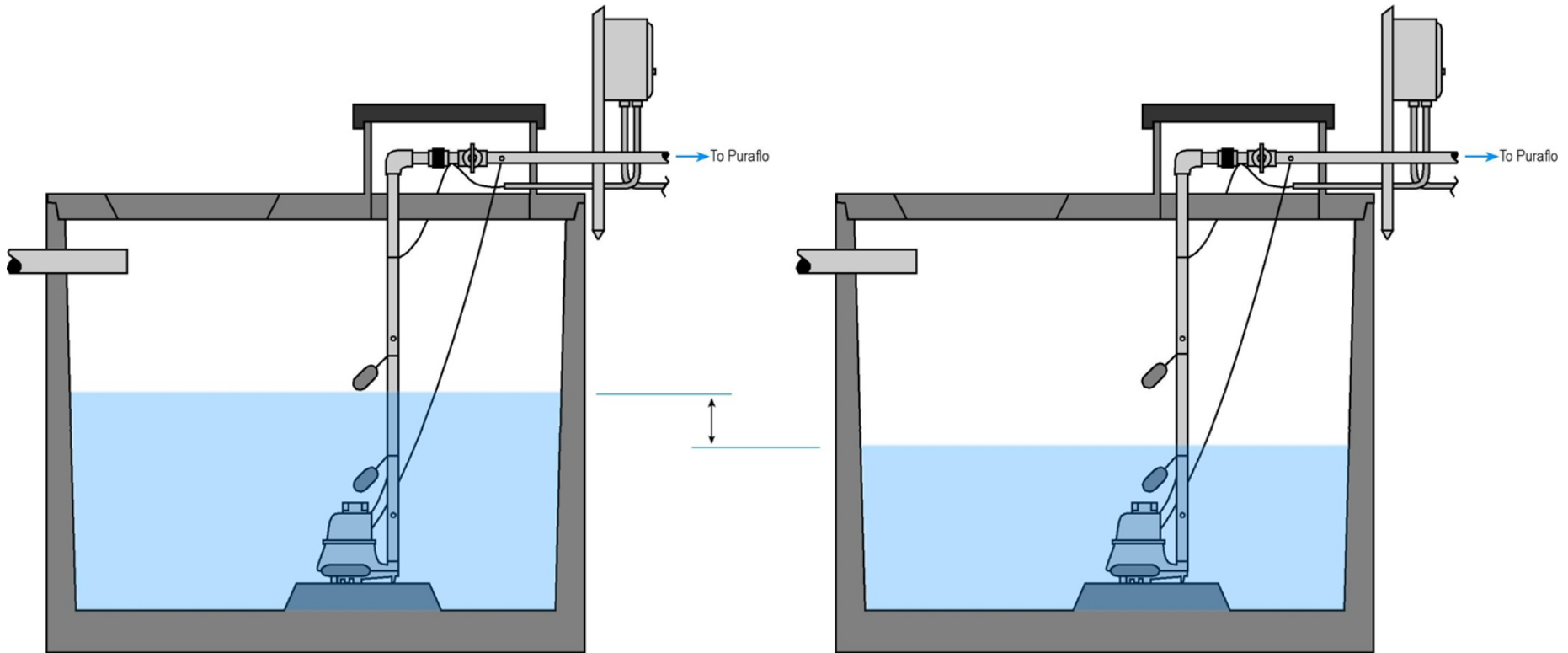

## STEP 1

1. Record water level
2. Record time
3. Turn pump "on"

## STEP 2

1. Turn pump "off"
2. Record water level
3. Record time
4. Record water level difference and elapsed time

# Start-up & Annual Service

## Drawdown Test Calculation Sheet

Directions: Fill-in applicable cells in **GREEN**. Answers appear in **BLUE**.

©2016 Anua

### Gallons Per Inch

Tank Type				Project Info	
Round		Rectangular			
Tank or Pipe dia. (inches)	76.8	Tank Length (inches)	96.5		
Volume (ft <sup>3</sup> ) per ft	32.15	Tank Width (inches)	47.9		
Gallons per inch	20.04	Volume (ft <sup>3</sup> ) per ft	32.10		
		Gallons per inch	20.01		

### Drawdown Test

Tank Type				Use this column if gals per in known	
Round		Rectangular		Tank	
Design flow (gpd)	360	Design flow (gpd)	360	Gallons per inch	20.00
Drainback vol. per dose (gal)	5	Drainback vol. per dose (gal)	5	Design flow (gpd)	600
# Puraflo <sup>®</sup> modules	3	# Puraflo <sup>®</sup> modules	3	Drainback vol. per dose (gal)	10
# doses per day	12	# doses per day	12	# Puraflo <sup>®</sup> modules	4
Drawdown (inches)	2.00	Drawdown (inches)	2.00	# doses per day	12
Elapsed time (minutes)	1.50	Elapsed time (minutes)	1.50	Drawdown (inches)	3.00
"ON" timer setting, mins	1.31	"ON" timer setting, mins	1.31	Elapsed time (minutes)	1.50
"ON" timer setting, secs	78.58	"ON" timer setting, secs	78.72	"ON" timer setting, mins	1.50
Dose volume per module	10.0	Dose volume per module	10.0	"ON" timer setting, secs	90.00
				Dose volume per module	12.5



# O&M Observation & Monitoring

- Check effluent levels in septic tank & pump tank
- Check commercial effluent filter for clogging
- Check watertightness of tanks, risers, lids, & pipe connections
- Check operation of pumps, floats, electrical controls, & alarms



# O&M Observation & Monitoring

- Confirm modules are accessible
- Check for any structural damage
- Check for adequate ventilation
  - Air holes free from obstruction
- Check for any odors
- Check for any berm damage
- Check condition of curtain drains



# O&M Observation & Monitoring

- Record peat fiber condition
- Check for insect or pest infiltration
- Check for evidence of continuous ponding
- Confirm even distribution of effluent between modules
- Confirm even distribution of effluent within each module
- Check for broken piping inside modules
- Check orifice disc inside union if module flow is uneven
- Check Spray heads and orifices for obstructions



# O&M Observation & Monitoring

- Check & record compaction level
  - Peat fiber settles over time
- Record color of peat fiber dark brown
- Check for biomat formation peat fiber color will be black
- Check the media for aerobic or anaerobic conditions
- Peat fiber saturation &/or anaerobic conditions can result in premature breakdown

# Site Restoration



# Site Restoration



# Site Restoration



# O&M Observation & Monitoring



- ✓ Check berms
- ✓ Check downslope for effluent leakage

# O&M Observation & Monitoring



# O&M Observation & Monitoring

- Aerobic



Anaerobic



- Puraflo modules must be **FREE DRAINING**

-

# Foam Cubes



# Issues Where Media Life Suffers

- Alarm Events
  - Water usage
  - Pump Performance
- Bottom-up
  - Restriction downstream
    - High water table
    - Pipe blockage
- Top-down
  - Heavy accumulations of various matter
  - Large areas of gray or black



# Measure & report

- Septic tank sludge & scum levels
- Pump tank sludge level & presence of grease
- Pump delivery rate (drawdown test) & dose volume
- Calculate & record average pump run time
- Record pump ETM & CT readings
- Report all system observations



# Hydraulic & Organic Overload

- Septic tank water level has been high



# Hydraulic & Organic Overload

- Peat fiber is saturated & losing structure
- BOD & TSS samples still under 30:30 mg/l



# Peat Replacement Overview

- Was the old media removed, including stone?
- Were drain or weep holes free from obstructions and free-draining?
- Are bars stable and connected?
- Is inlet piping stable and connected?
- Was one bag or 1,000 lbs of peat fiber media installed under grid?
- Was piping flushed before grid was installed?
- Was orifice checked and cleaned?
- Was grid replaced and strapped / connected correctly?
- Was flow through grid checked for even flow? (adjust as needed)
- Was 1/4 bag or 250 lbs of peat fiber media installed on top of grid?
- Was lid re-installed properly and secured with lid bolts?
- Was drawdown test performed and the control panel timer set correctly?
- Was effluent free-flowing into the sample chamber after drawdown test?

# Peat Replacement Overview

- Ensure old peat fiber & stone is removed!



# Peat Replacement Overview

- Place clean stone (3/4" to 1")
- 4.5 ft<sup>3</sup>, or 5-gallon bucket x 7



# Peat Replacement Overview



# Peat Replacement Overview

- Place peat fiber in modules up to 2<sup>nd</sup> step (1/2 bag)
  - Walk on it in a sequential manner to compact it
- Fill remaining module with peat fiber to grid level (1/2 bag)
  - Walk on it in a sequential manner to compact it
- Run pump again to clean out inlet piping
- Replace grids & run pump
  - Ensure all grids are receiving same amount of water
  - Ensure all grids are evenly dispersing water over media
  - Push or pull stabilizer bars to level grids, as needed

# Peat Replacement Overview

- Place peat fiber to 6" above grid (1/4 bag)
- Level peat fiber
- Pack top peat fiber lightly
- DO NOT step on grid



# How To Sample

- Follow procedures in O&M manual
- Don't "force" sample by manually activating pump!

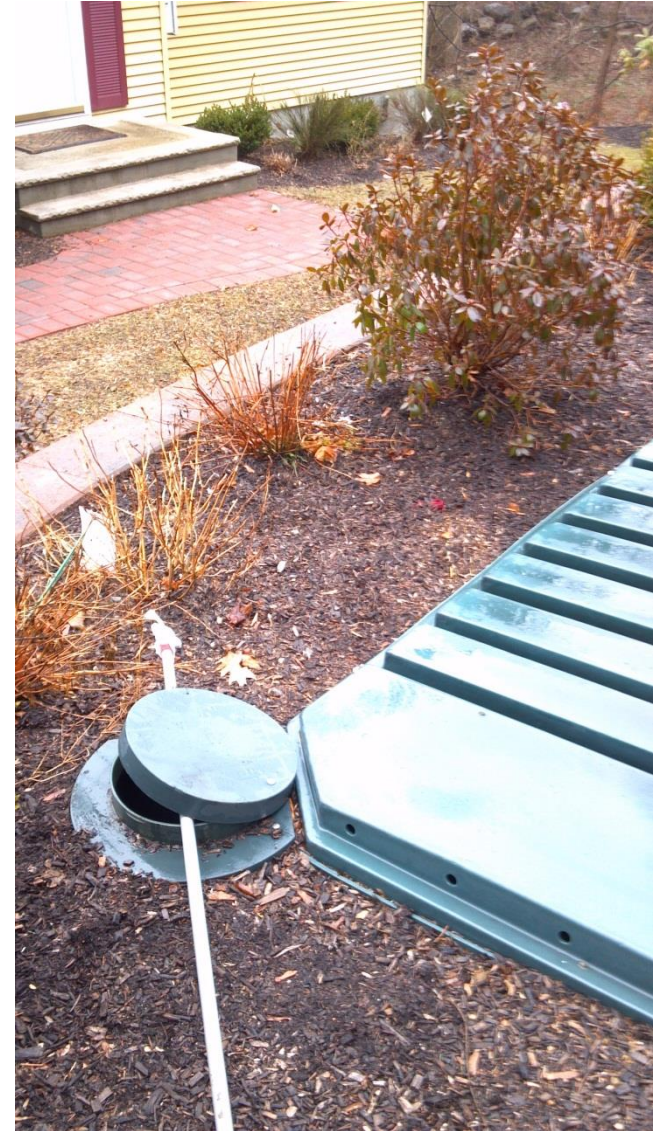

# How To Sample

- Inside sample chamber



# How To Sample

- Visual of effluent quality
- Effluent can have slight tint due to tannins in peat
- Clarity should be clear, not cloudy



# System Tracking & Reporting



P.O. Box 77457  
Greensboro, NC 27417

T 336-547-9338  
F 336-547-8559  
www.anua-us.com



P.O. Box 77457  
Greensboro, NC 27417

T 336-547-9338  
F 336-547-8559  
www.anua-us.com

## Treatment System Tracking Sheet

### GENERAL INFORMATION

Owner:  Distributor:

Permit No.:  Phone:  Email:

System Address:

Town/City:  County:  State:  Zip:

Legal Description:  Tax ID No.:

### PROJECT ENGINEER OR DESIGNER

Name and Company:

Phone:  Email:

Address:  City:  State:  Zip:

### AUTHORIZED INSTALLER\*

Name and Company:

Phone:  Email:

Address:  City:  State:  Zip:

### SERVICE PROVIDER\*\*

Name and Company:

Phone:  Email:

Address:  City:  State:  Zip:

\*As a condition of operation, the design and installation instructions must be followed. The system shall be constructed in accordance with the approved plans and manufacturer specifications. The installer or system owner should provide installation photos, soil reports, permit documents and other pertinent information to demonstrate that the design and installation instructions were followed. Prior to placing the new system into operation, the permittee is responsible for ensuring that the administrative authority and the project engineer or designer verify the following:

- 1) All treatment system components, primary tanks, dosing tanks, access ports, access port covers and the collection system were properly installed, vented and tested to ensure they do not leak nor allow groundwater or surface water infiltration.
- 2) All system components were installed per the approved plans and manufacturer specifications.
- 3) All mechanical components (e.g. panels, pumps, alarms, level controls and air compressors) were properly installed, calibrated and tested.
- 4) All required health department, plumbing, electrical and/or building permits were obtained from the responsible administrative authority.
- 5) The dispersal system was installed in the approved location, at the proper depth, on natural contours and with minimal disturbance of native vegetation or soil.
- 6) The system is permanently protected from vehicular traffic, compaction, surface water run-off, irrigation and roof drains.
- 7) Upon final inspection and approval from administrative authority and project engineer or designer, the system is deemed fully operational.

\*\*A service agreement between the service provider and the system owner is required as a condition of warranty. A service provider, who has been trained by the manufacturer or the manufacturer's authorized representative, must perform the service. The initial agreement should cover a two-year period, minimum, or as specified by the administrative authority.

### SYSTEM INFORMATION

PLATINUM	DESIGN FLOW: <input type="text"/>	DATE INSTALLED: <input type="text"/>
Gravity discharge: <input type="checkbox"/>	No. of units: <input type="text"/>	Facility type:
Pumped discharge: <input type="checkbox"/>	No. of units: <input type="text"/>	Residential <input type="checkbox"/> Commercial <input type="checkbox"/>
Model:		
APG6 <input type="checkbox"/> APP6 <input type="checkbox"/> APG8 <input type="checkbox"/> APP8 <input type="checkbox"/>		
APG10 <input type="checkbox"/> APP10 <input type="checkbox"/> APG12 <input type="checkbox"/> APP12 <input type="checkbox"/>		
Serial Number(s):		
Unit: <input type="text"/>	Air comp: <input type="text"/>	Panel: <input type="text"/> Pump: <input type="text"/>

PURAFLO	DESIGN FLOW: <input type="text"/>	DATE INSTALLED: <input type="text"/>
Facility type: Residential <input type="checkbox"/> Commercial <input type="checkbox"/>	Effluent prior to Puraflo: Primary (septic) <input type="checkbox"/> Secondary <input type="checkbox"/>	
Blue coded module: <input type="checkbox"/>	No. of modules: <input type="text"/>	SN: <input type="text"/>
Green coded module: <input type="checkbox"/>	No. of modules: <input type="text"/>	SN: <input type="text"/>
White coded module: <input type="checkbox"/>	No. of modules: <input type="text"/>	SN: <input type="text"/>
Septic tank mfg: <input type="text"/>	Capacity: <input type="text"/>	Material: Concrete <input type="checkbox"/> Fiberglass <input type="checkbox"/> Plastic <input type="checkbox"/>
Pump tank mfg: <input type="text"/>	Capacity: <input type="text"/>	Material: Concrete <input type="checkbox"/> Fiberglass <input type="checkbox"/> Plastic <input type="checkbox"/>
Effluent filter(s): Zabel A300 <input type="checkbox"/> Polylok PL-625 <input type="checkbox"/> BEST GF-1032 <input type="checkbox"/> Bear Onsite ML3-932 <input type="checkbox"/> Sim/Tech STF-100 <input type="checkbox"/>		
Anua sample chamber(s)?: Yes <input type="checkbox"/> No <input type="checkbox"/>	Panel mfg: <input type="text"/>	SN: <input type="text"/>
Puraflo timed dose pump mfg: <input type="text"/>	Model: <input type="text"/>	SN: <input type="text"/>

EFFLUENT DISPERSAL METHOD	DESIGN FLOW: <input type="text"/>	DATE INSTALLED: <input type="text"/>
In-ground pad <input type="checkbox"/> Mounded pad <input type="checkbox"/> Stone trench <input type="checkbox"/> Chamber <input type="checkbox"/> Polystyrene aggregate <input type="checkbox"/> Drip <input type="checkbox"/> Other <input type="checkbox"/>		

— FILL AND SAVE USING FOXIT READER. DOWNLOAD AT: [HTTP://WWW.FOXITSOFTWARE.COM/SECURE\\_PDF\\_READER/](http://www.foxitsoftware.com/secure_pdf_reader/) —

— TO ACTIVATE WARRANTY EMAIL COMPLETED SHEET TO: [INFO@ANUA-US.COM](mailto:INFO@ANUA-US.COM) —

# Contact

[www.anuainternational.com](http://www.anuainternational.com)

