

# BioMicrobics FAST<sup>®</sup> O & M Training

Daniel Westrich  
Manager of Regulatory Affairs

# About BioMicrobics



1996

BioMicrobics was founded

90+

Countries

90,000

Systems Operating

30+

Products for wastewater & stormwater industries

## Certifications



TOP 10 PRODUCT FOR 2017

Bio-Microbics d-Rain Joint Rainwater Filter



Certified to NSF/ANSI Standards 40 & 245



Certified to CAN/BNQ 3680-600

# Agenda



MicroFAST® Overview

MicroFAST® Overview



System Components

Nitrogen Removal



Treatment Process

Lid Option Installation



Installation Options

Blower Installation



Installation Procedures

Basic O&M



# FAST<sup>®</sup> Overview

Used in marine, residential, commercial, industrial, and municipal treatment markets



The FAST<sup>®</sup> system is a robust and simple aerobic treatment package utilizing a submerged, fixed-film activated sludge technology. It has been engineered with **ease of operation and maintenance** in mind.

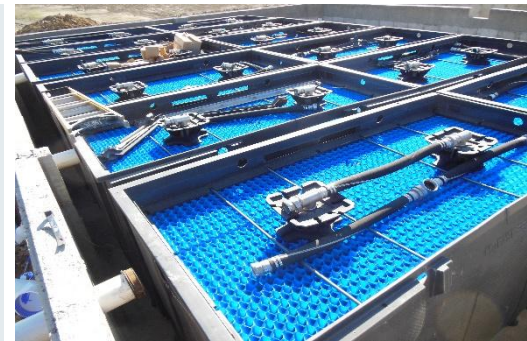



Successfully used for **over 40 years**, the FAST<sup>®</sup> technology is used to treat domestic and high strength wastewater, including nitrogen and other nutrients.







Once installed, this wastewater treatment system is completely self-contained **and uses only active, naturally occurring microorganisms** to treat wastewater to the designed effluent requirements.

# FAST<sup>®</sup> Products

## RetroFAST<sup>®</sup> wastewater treatment systems

0.150	150 GPD	
0.250	250 GPD	
0.375	375 GPD	

## MicroFAST<sup>®</sup> wastewater treatment systems

Flex 0.4	400 GPD	
Flex 0.5	500 GPD	
0.5	500 GPD	
0.625	625 GPD	
0.75	750 GPD	
0.9	900 GPD	
1.5	1500 GPD	
3.0	3000 GPD	
4.5	4500 GPD	
9.0	9000 GPD	

## HighStrengthFAST<sup>®</sup> wastewater treatment systems

1.0	1000 GPD
1.5	1500 GPD
3.0	3000 GPD
4.5	4500 GPD
9.0	9000 GPD

## MyFAST<sup>®</sup> wastewater treatment systems

1.0	10000 GPD
2.0	20000 GPD
3.0	30000 GPD
4.0	40000 GPD
6.0	60000 GPD
8.0	80000 GPD
12.0	120000 GPD
16.0	160000 GPD

# General Layout

- A. Blower and Housing
- B. Control Panel
- C. Air Line Piping
- D. Vent(s) and Observation Port
- E. Access
- F. FAST<sup>®</sup> Unit
- G. Tank
- H. Outlet to Drainfield

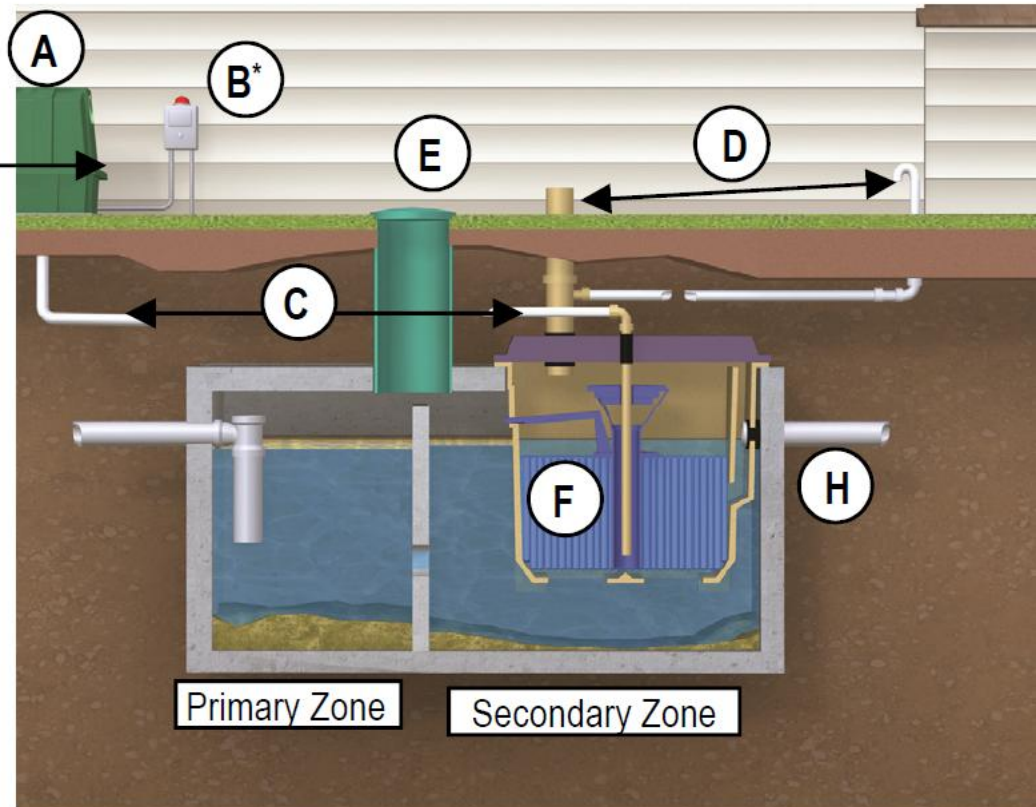

# System Components

1. Blower Housing
2. Blower (with blower I/O piping, Inlet Filter Assembly (blower and housing screws not shown))
3. Louver
4. Liner
5. Recirculation Trough
6. Air Lift
7. 4" Outlet Gasket
8. Foot Top (foot option)
9. Foot Bottom (foot option)
10. Foot Screws (foot option)
11. 6" Observation Port Gasket (lid option)
12. 2" Air Line Gasket (lid option)
13. Lid

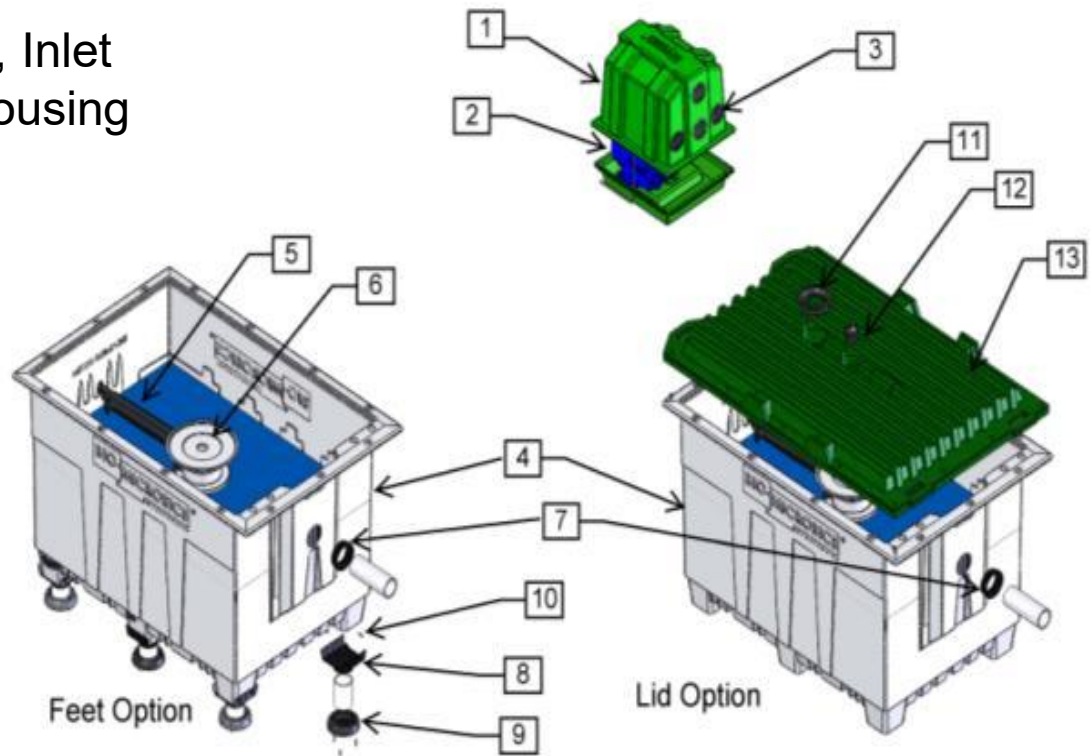

# System Components

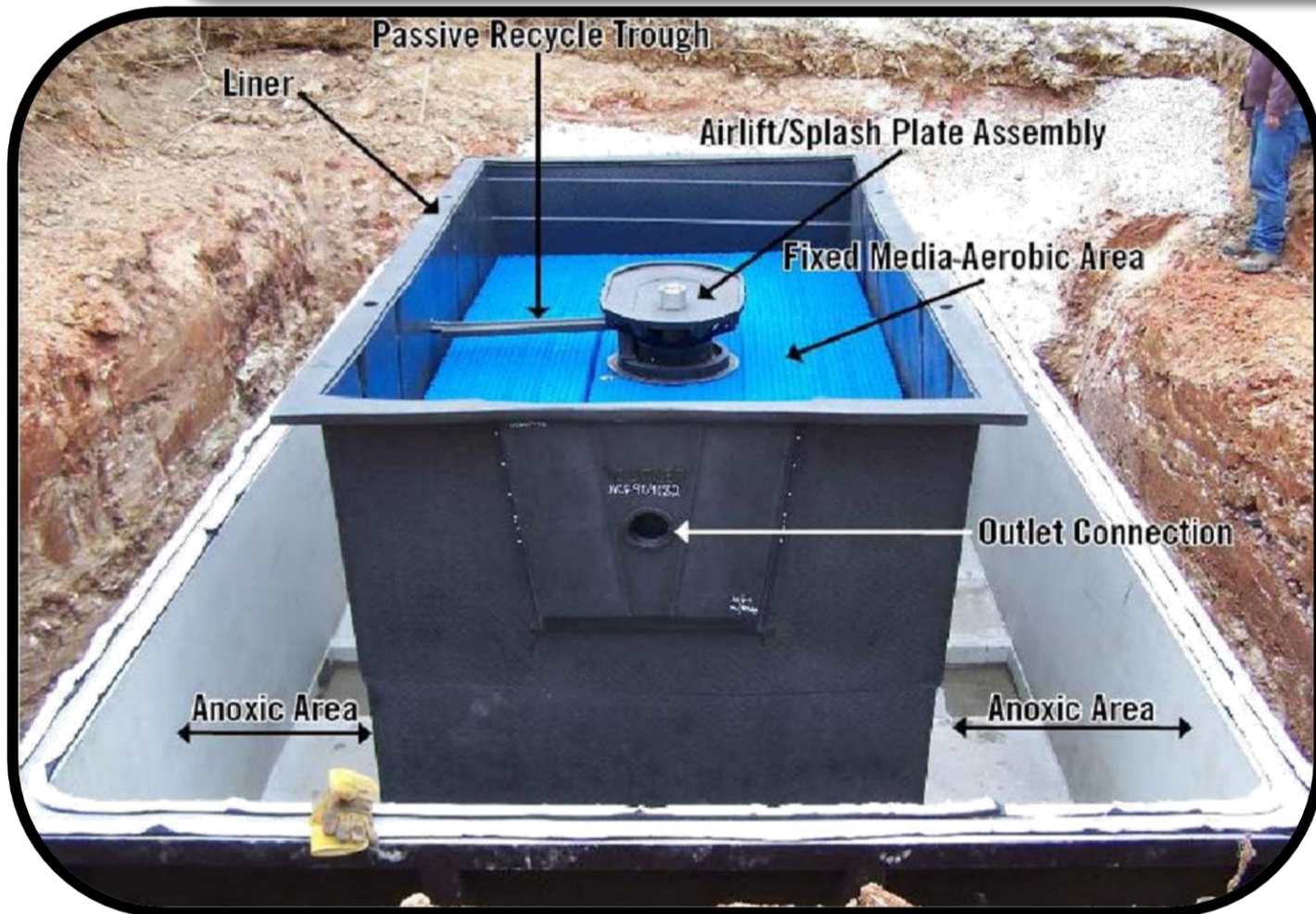

# Treatment Process

1. Influent
2. Settling Tank
3. SaniTEE® Screen
4. Aeration
5. FAST® wastewater treatment system
6. Discharge

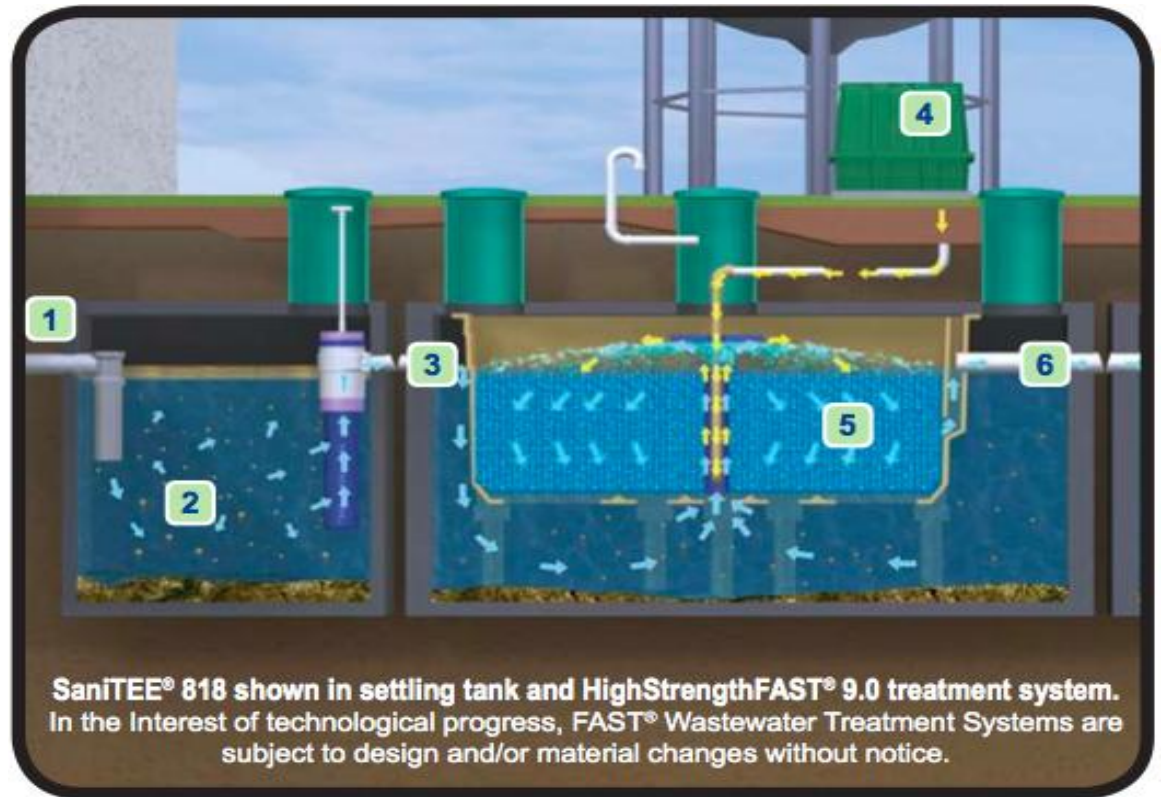

# Treatment Process

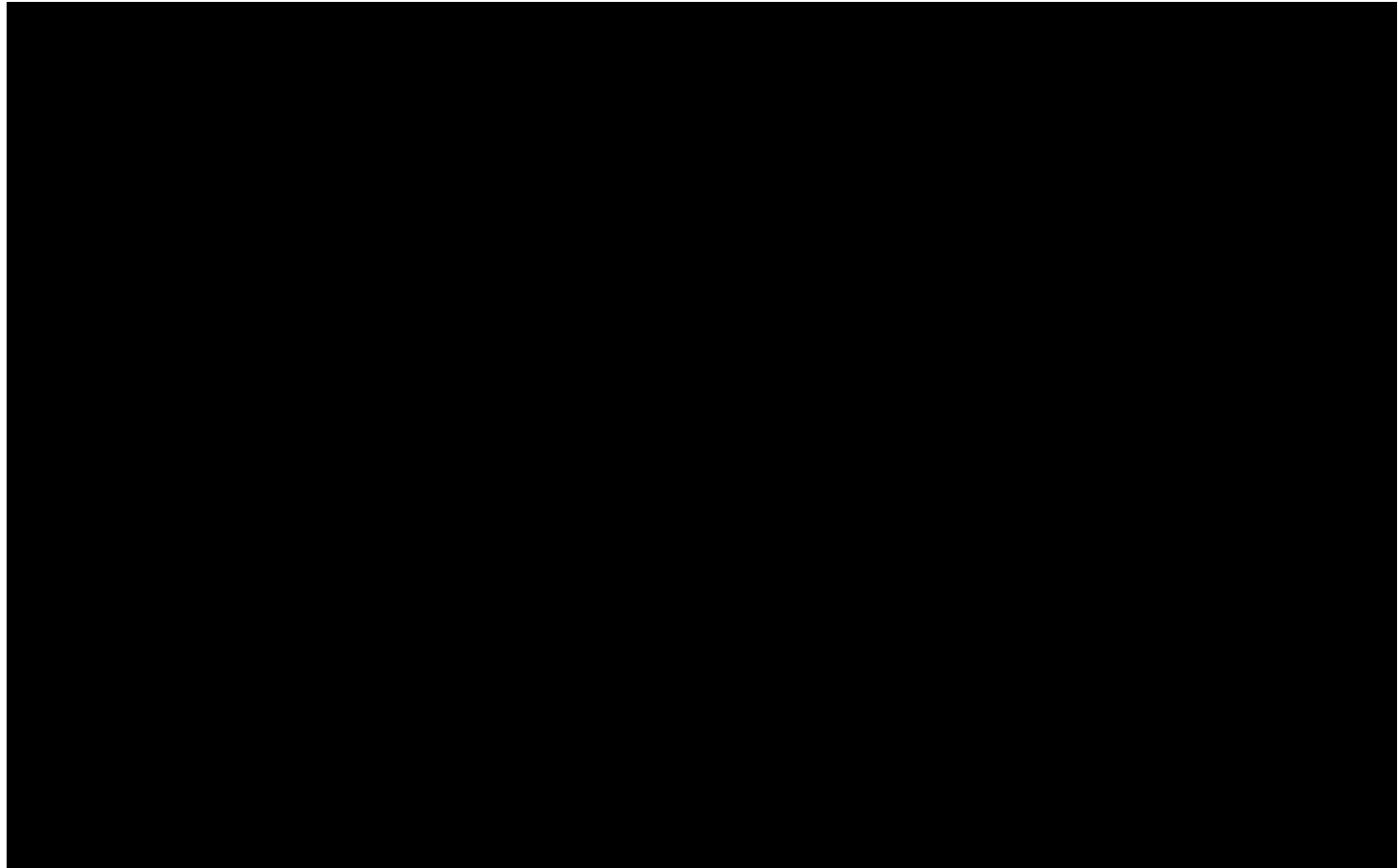

# Treatment Process



Settling Tank Followed By  
Treatment Tank with MicroFAST®



Open Bottom For  
Sludge Storage

A dynamic splash of clear blue water against a white background, with several droplets suspended in the air. The splash originates from the right side and moves towards the left.

# FAST<sup>®</sup> Installation Procedures

# Installation Options

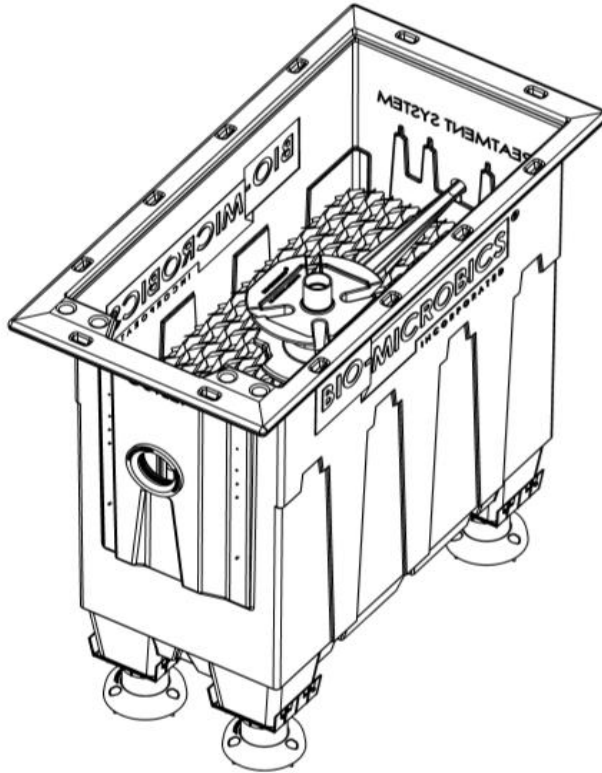

MICROFAST® 0.50 WITH FEET

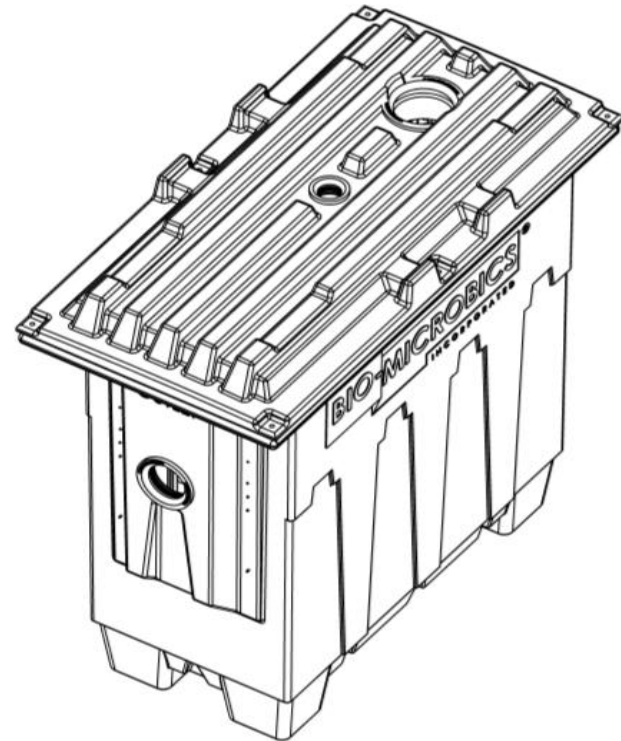

MICROFAST® 0.50 WITH LID

# Lid Installation



Pre-cast tank with observation port, pump-out port, and cutout for FAST® system



Use appropriate sealant to seal FAST® liner to tank

# Lid Installation



MicroFAST® liner hangs from the top of the tank opening

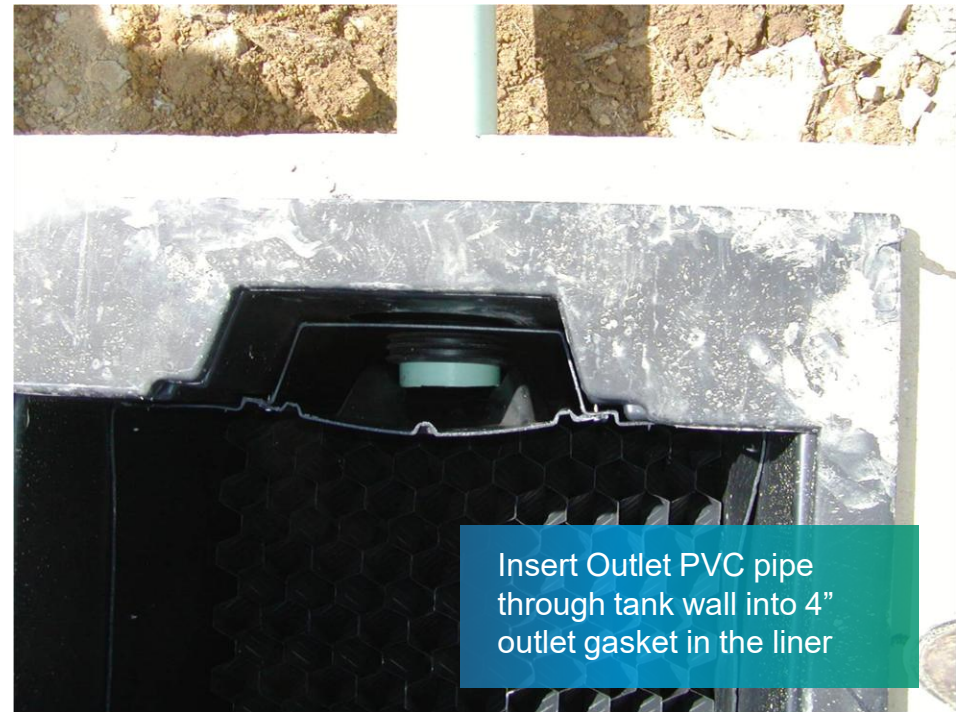

Insert Outlet PVC pipe through tank wall into 4" outlet gasket in the liner

# Lid Installation

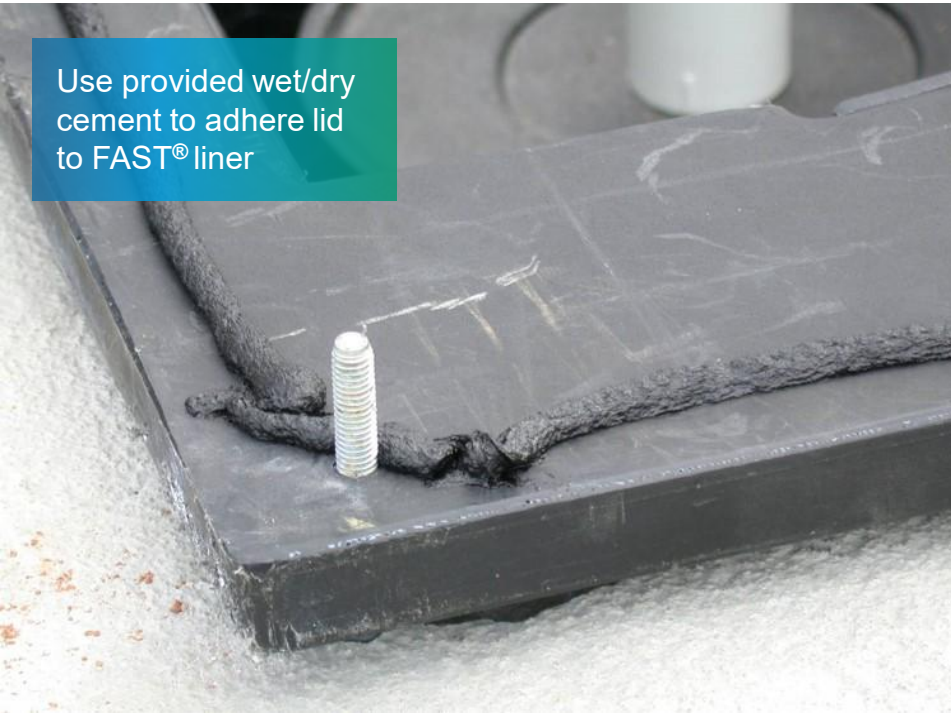

Use provided wet/dry cement to adhere lid to FAST® liner



Place lid on top of liner and secure with 3/8" bolts

# Air Line Connection

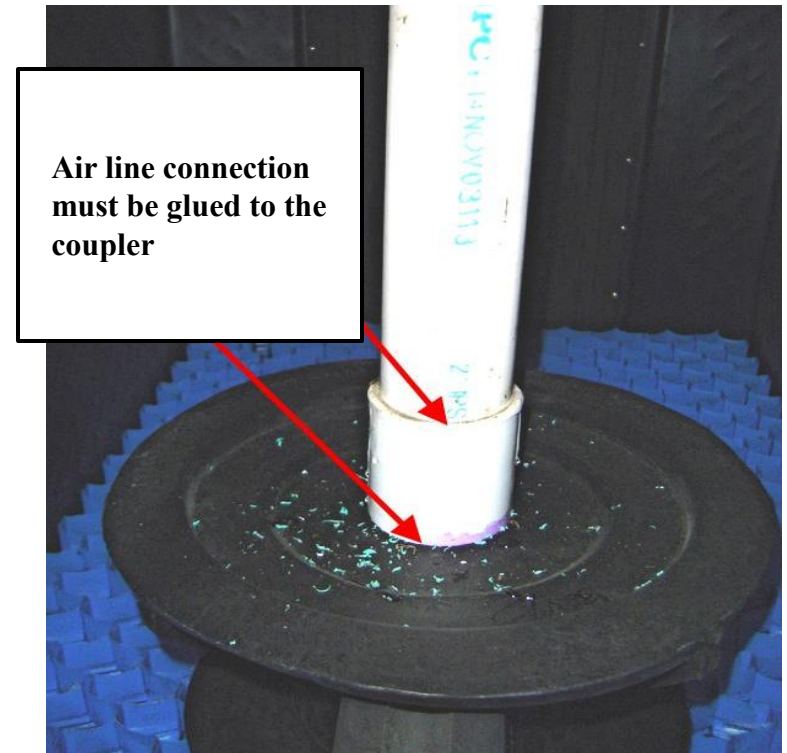
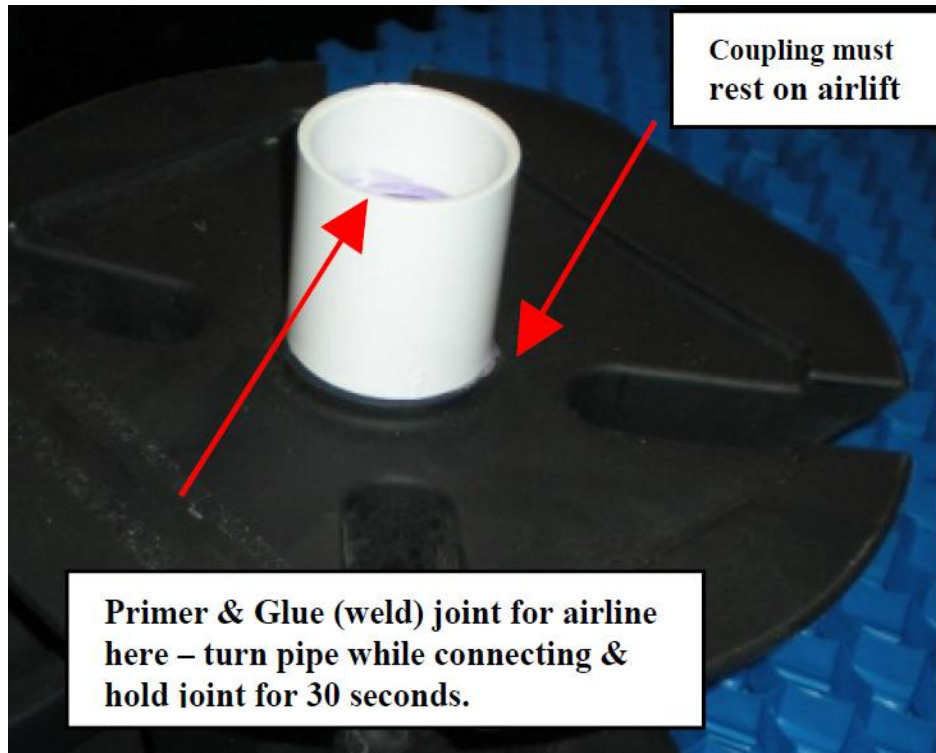

# Air Line and Observation/Vent Port

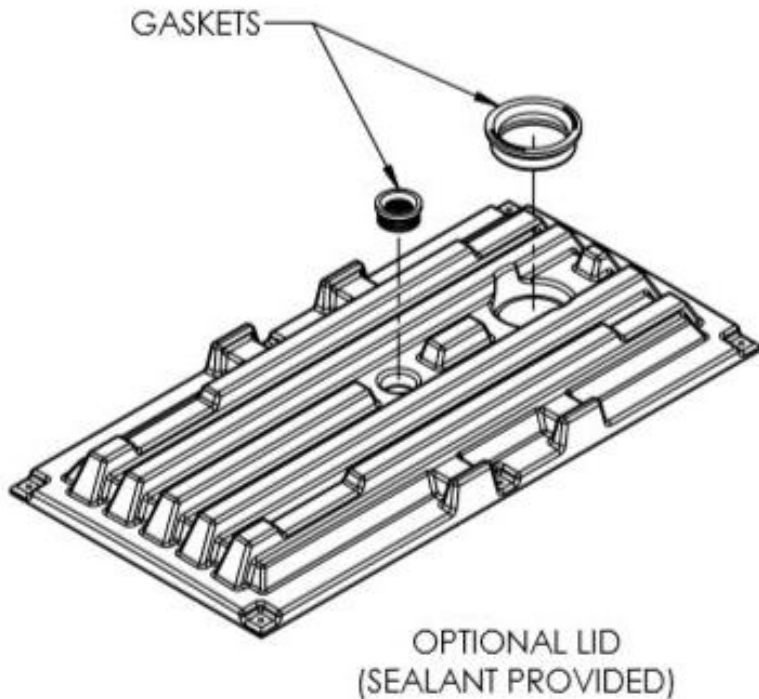

Insert the air line pipe into the provided gasket, then into the access hole in lid.



Insert the observation/vent port into the provided gasket, then into the access hole in lid



# Air Line and Observation/Vent Port

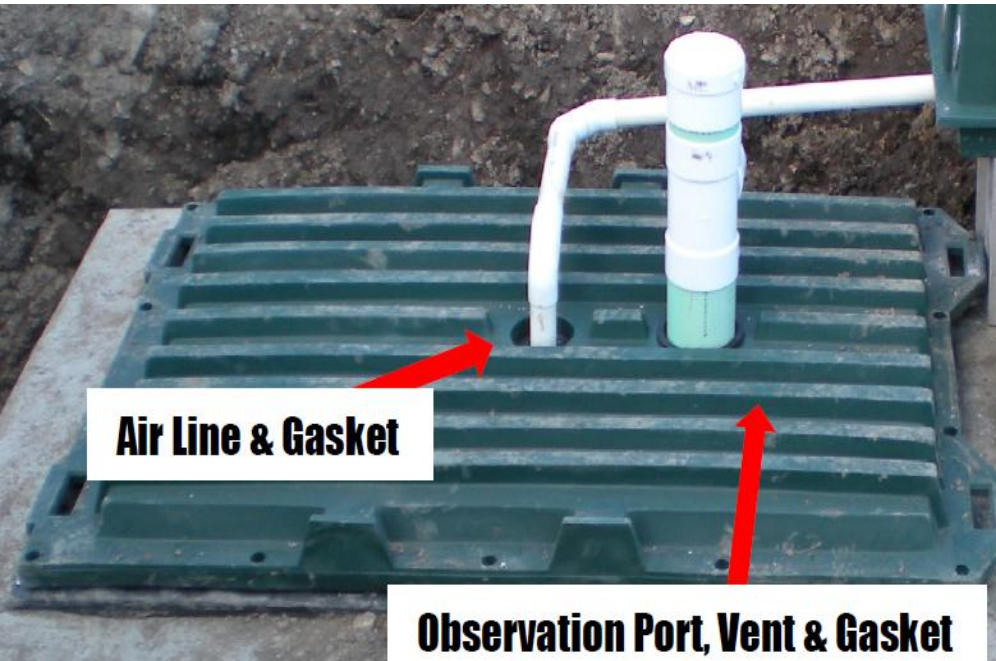

# Feet Installation

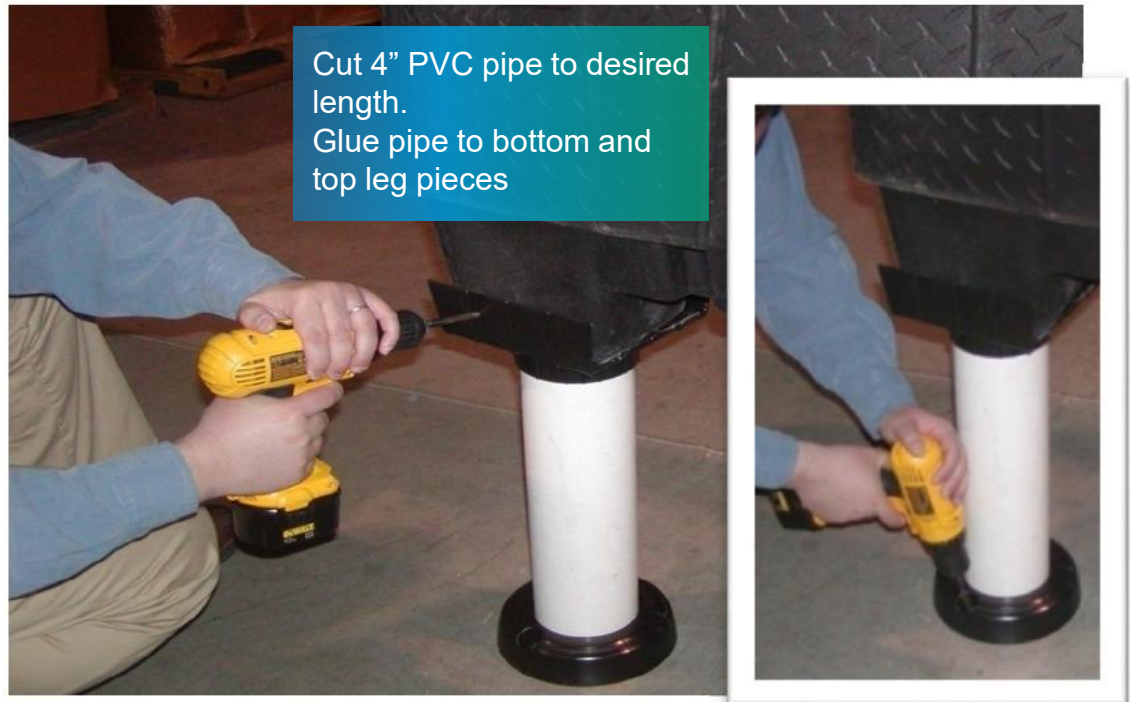
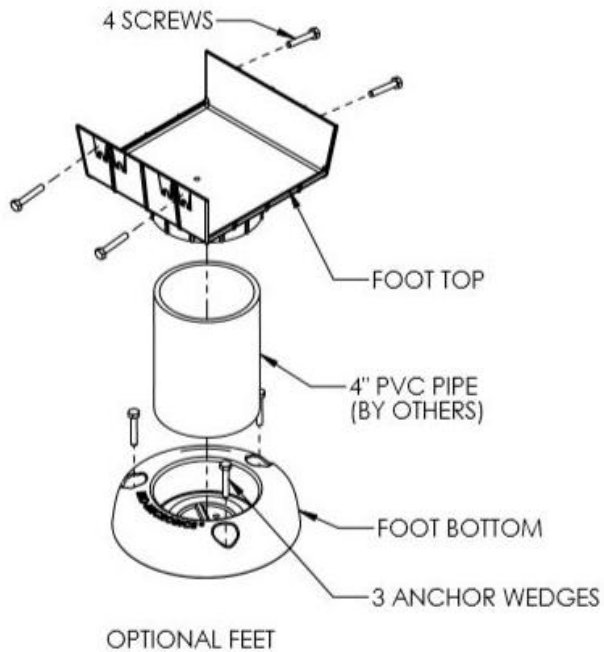

# Feet Installation

Attach leg extensions to the FAST® module using supplied self-tapping screws



Attach leg extensions to the base of the tank with anchor bolts (not provided)

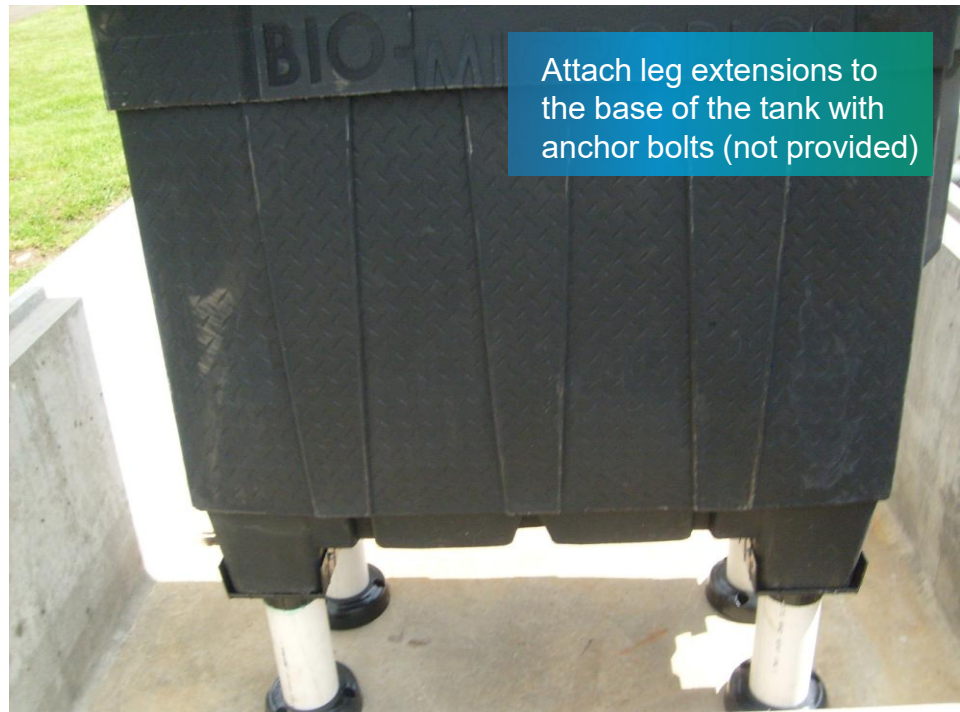

# Feet Installation

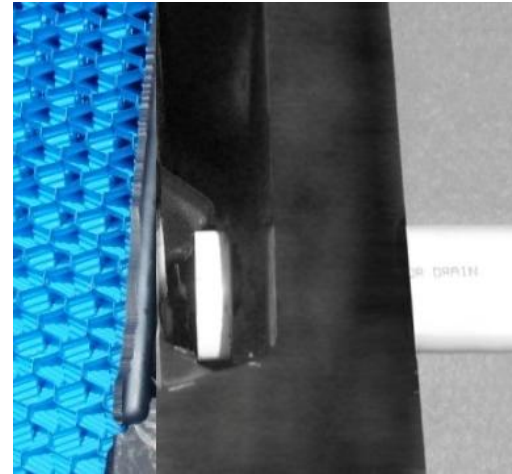

Legs can be attached prior or during tank installation.

Insert Outlet PVC pipe through tank wall and into 4" outlet gasket in the liner

# Pump Out Access

Access over baffle wall



Tank with pump-out access



# Venting

## Most Common Venting Options

### Direct Vent

The 6" o/v port can have holes drilled in it or a slotted cap put on it. The opening(s) should prevent foreign material from entering the system.

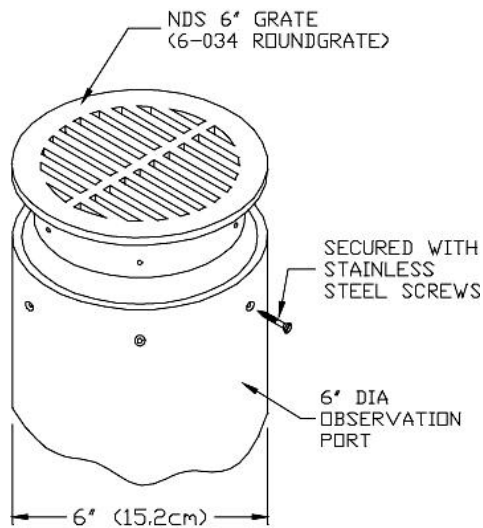

### Remote Vent

Branch off of the 6" o/v port or manhole below grade. Run the vent pipe to the desired location and terminate above grade. Cover opening with #4 mesh screen or similar.

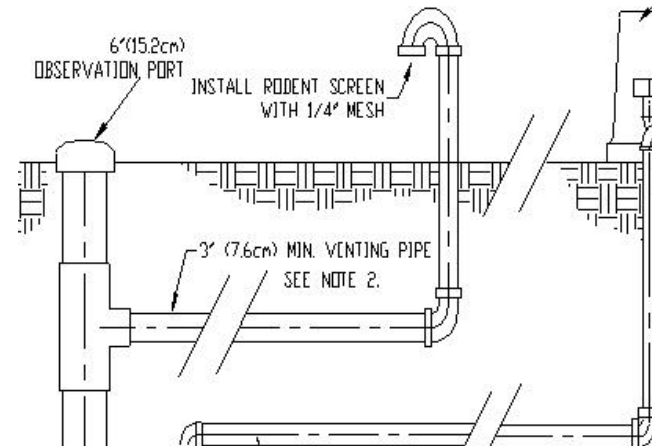

# Other Venting Options



Charcoal filters and buried vents can be used as well.

Venting options must not allow surface water to enter the system and must allow internal condensation to drain



Call Us Today for more information  
(800) 622-8768 or (530) 622-8768



# Correct vs Incorrect Venting



Proper Venting



Inadequate Venting

# Blower Installation

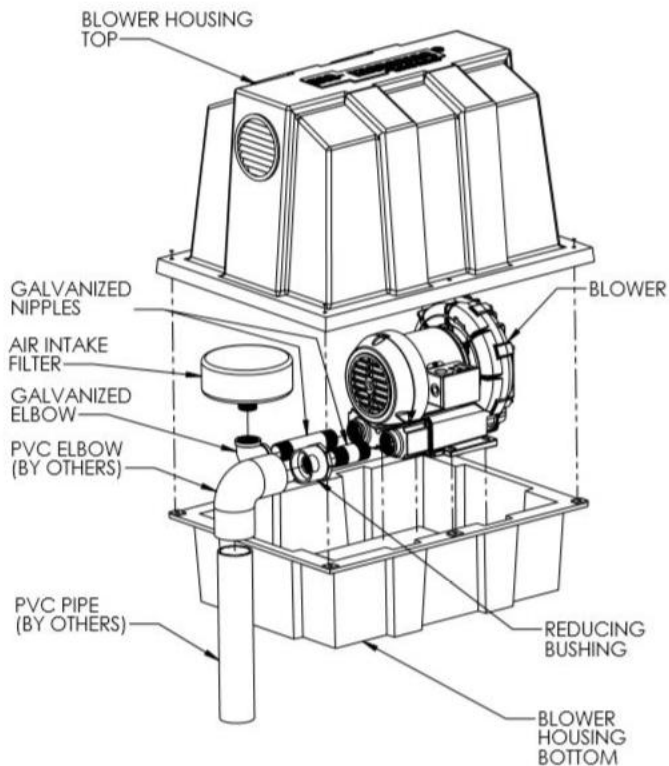

Blower and blower housing must be mounted to a solid base to avoid settling



Connect airline from FAST® to blower outlet using required piping. Connect incoming power to the blower at the blower junction box

# Blower Piping



Blower piping may not exceed 4 elbows

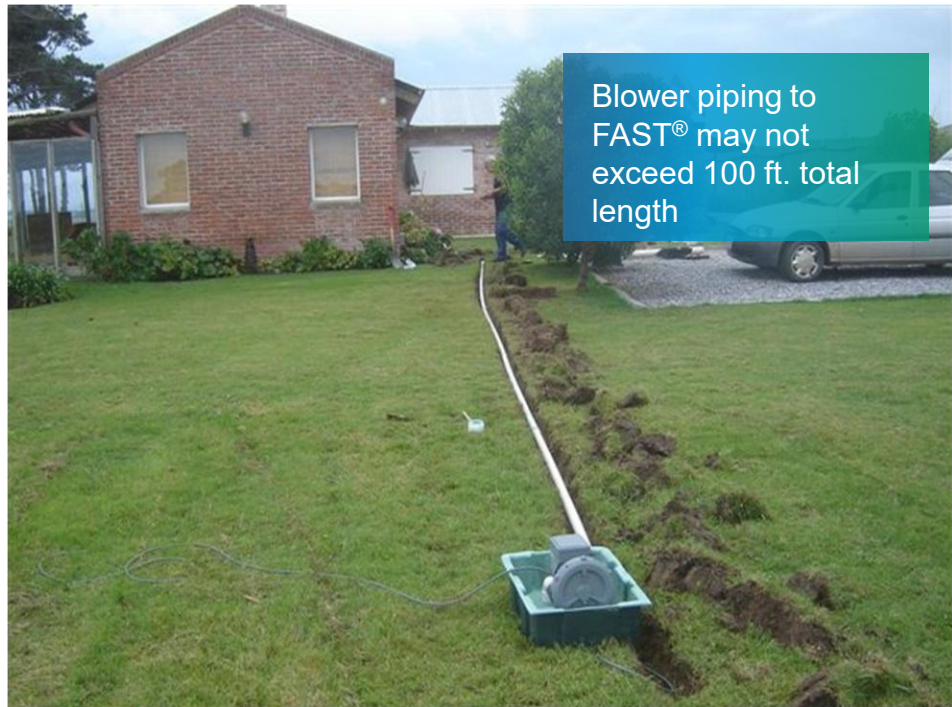

Blower piping to FAST® may not exceed 100 ft. total length

# Blower Piping and Connections

## Rule #1

- Don't over-excavate or pipes will sag or break
- If you break Rule #1, refill and compact native soil or use sand or gravel



# Blower Piping and Connections

## Rule #2

- Support pipes of deep excavations where pipes have to leave or enter tanks or they will break when they settle
- Use sand or gravel (not too large) and use at least Schedule 40 pipe.



# Blower Piping and Connections

## Rule #3

- Use good backfill material free of large rocks or dry heavy clay.
- Minimize weight by using granular backfill



# Control Panel Installation

**WARNING:** All electrical work should be performed by a qualified electrician and per all applicable codes. Failure to do so may result in severe bodily injury or death.

Electrical panel and parts are ETL (UL equivalent) certified for safety. Control panel meets NEMA4X standards for all-weather use.

- A dedicated breaker is required in the building's master electrical panel
- Make connections between the master panel and FAST<sup>®</sup> control panel
- Make connections between blower and FAST<sup>®</sup> control panel per the electrical diagram
- The standard control panel supplied with FAST<sup>®</sup> system will alarm if the blower loses power, or the high pressure switch is activated.



Current Panel



Old Panel



Older Panel

# Control Panel Wiring Diagram

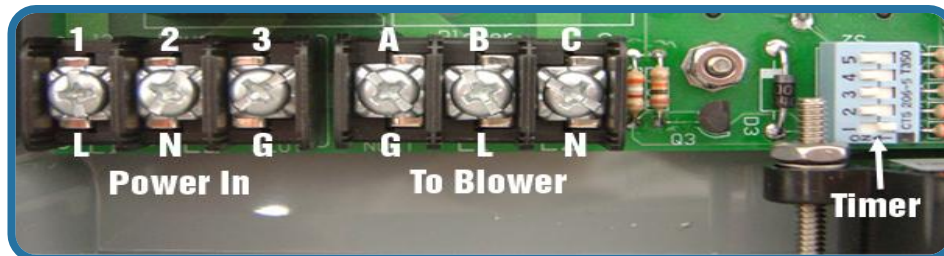
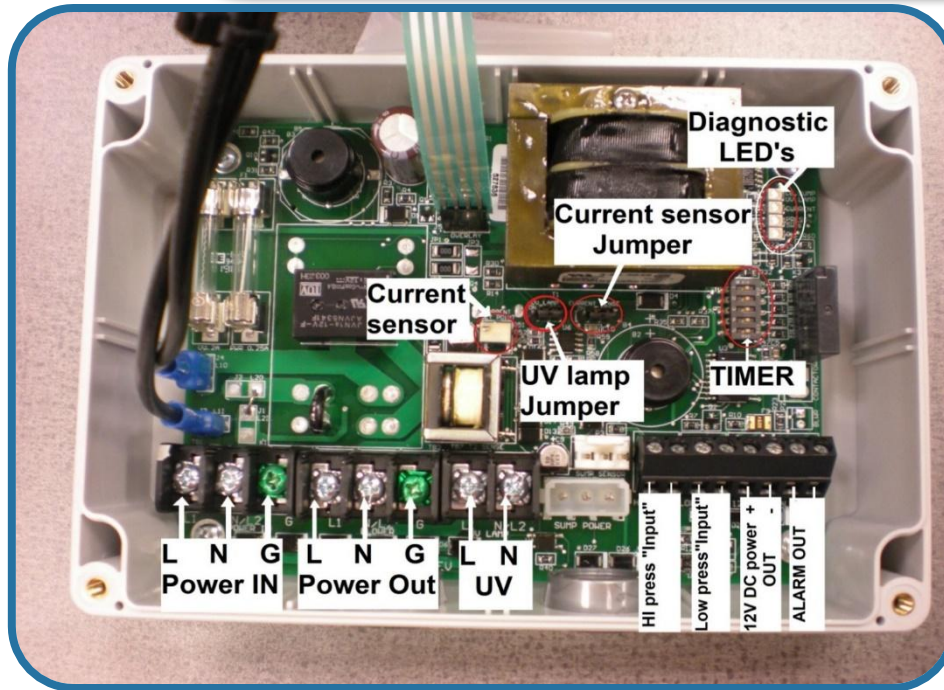

TIMING MODS					BLOWER MINUTES	
DIP SW POS. (S1)					ON	OFF
5	4	3	2	1	ON	OFF
Off	Off	Off	Off	Off	30	30
Off	Off	Off	Off	On	60	30
Off	Off	Off	On	Off	120	30
Off	Off	Off	On	On	180	30
Off	Off	On	Off	Off	240	30
Off	Off	On	Off	On	30	20
Off	Off	On	On	Off	60	20
Off	Off	On	On	On	120	20
Off	On	Off	Off	Off	180	20
Off	On	Off	Off	On	240	20
Off	On	Off	On	Off	30	10
Off	On	Off	On	On	60	10
Off	On	On	Off	Off	120	10
Off	On	On	Off	On	180	10
Off	On	On	On	Off	240	10
Off	On	On	On	On	30	45
On	Off	Off	Off	Off	60	45
On	Off	Off	Off	On	120	45
On	Off	Off	On	Off	180	45
On	Off	Off	On	On	240	45
On	Off	On	Off	Off	30	60
On	Off	On	Off	On	60	60
On	Off	On	On	Off	120	60
On	Off	On	On	On	180	60
On	On	Off	Off	Off	240	60
On	On	Off	Off	On	30	90
On	On	Off	On	Off	60	90
On	On	Off	On	On	120	90
On	On	On	Off	Off	180	90
On	On	On	Off	On	240	90
On	On	On	On	Off	TEST	
On	On	On	On	On	∞	

TEST = 15 SEC ON, 20 SEC PFF  
∞ = ALWAYS ON

Not Sure?

CALL  
800-753-FAST  
(3278)

# Other Wiring Diagrams

## Larger Panels

FAST® Control Panel - 3 Phase, with thermals

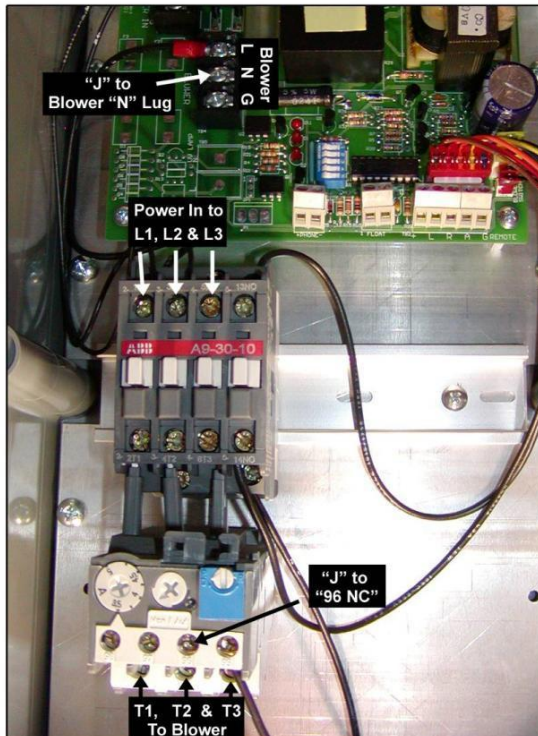

- Power In to L1, L2 and L3
- Remove existing wire between "96 NC" & Blower "N" Lug
- Two "J" wires from blower: connect one to (Blower "N" Terminal), and the other to overload "96NC" Terminal
- Power to Blower from T1, T2 and T3

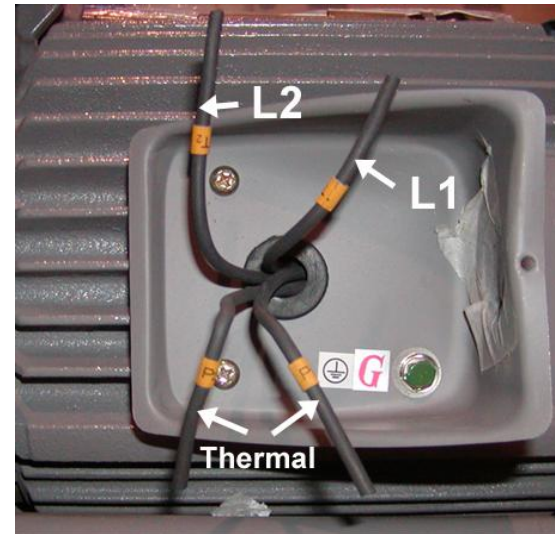

Model: FUJI VFC504P-2T

Power: 220V 1Ø

- L1 to T1
- L2 to T2
- P1 & P2 to panel for thermal protection

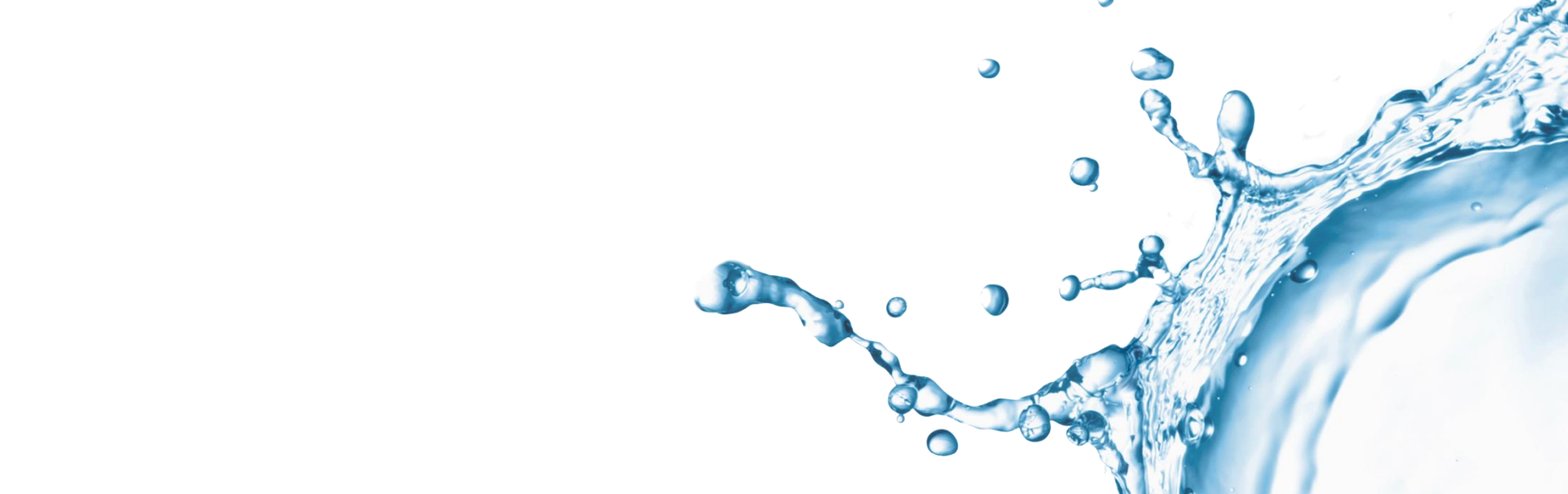

# FAST<sup>®</sup> Maintenance

# FAST<sup>®</sup> Maintenance Overview

- Keep the blower air inlet filter clean
- Observe aeration & splashing pattern in the tank
- Observe the media biofilm growth
- Measure sludge level in the tank & waste sludge if needed
- Observe effluent clarity

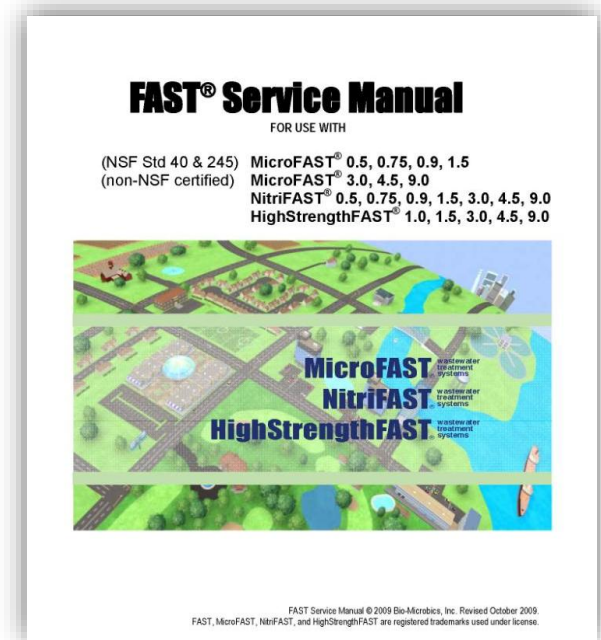

# Regenerative Blowers

- Requiring no V belts to replace or adjust and no oil to change, blower provides high performance with virtually no maintenance.
- Blower inside housing has a noise level below 80 decibels.

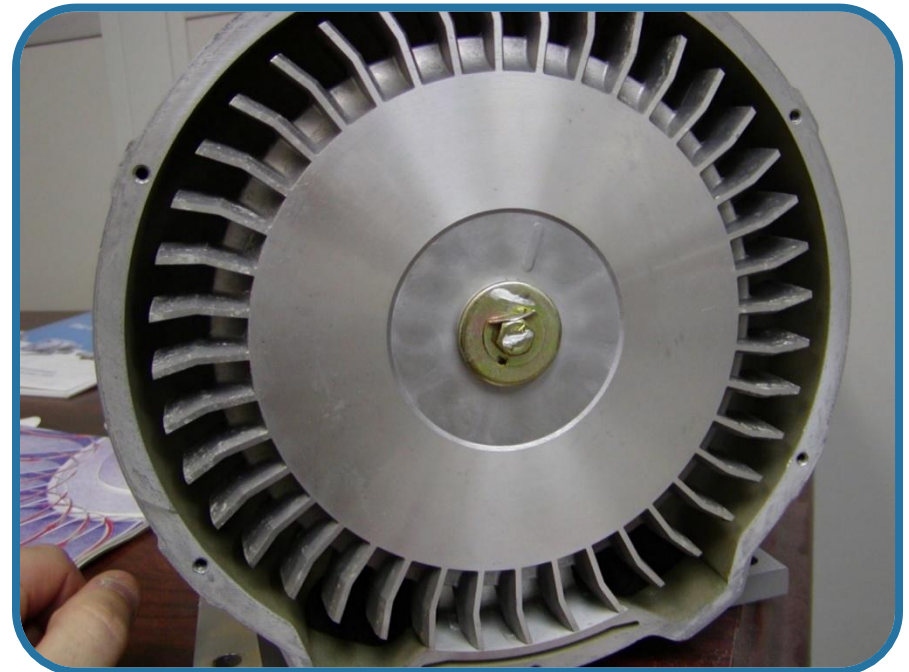

# Blower Operation

## KEEP THE BLOWER RUNNING

- Clean the steel air filter
- Keep housing free of debris
- Humming noise is normal
- Check proper venting (should be no back pressure)

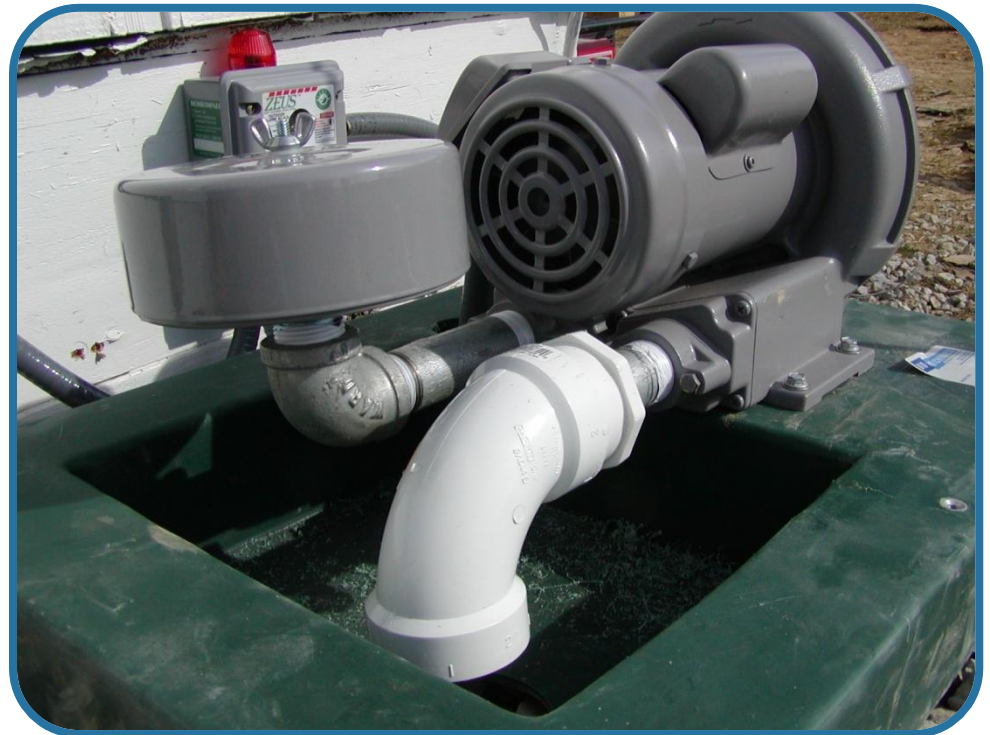

# Blower Maintenance



Remove inlet filter and examine the air filter element



Clean the blower's inlet air filter from any debris

# Splashing

## MAKE SURE THERE IS VIGOROUS SPLASHING

- Splash should be crisp, robust, and clean-sounding
- Water level should be 2-3 inches over the media



# High Water Level



# Biofilm Growth

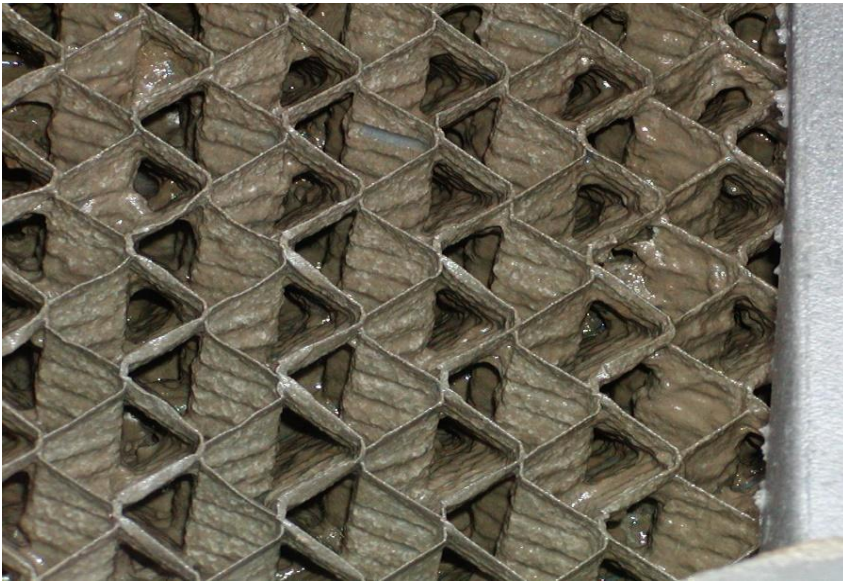

Normal Biofilm Growth on Media



Heavy Biofilm Growth on Media

# Measuring Sludge

## MONITOR SLUDGE IN BOTH COMPARTMENTS OR TANKS

- If depth of sludge is within 3-4 inches of bottom of FAST, pump-out is required.
- Use sludge judge and formula in service manual:

Total Water Depth – Unit Height =  
Total Sludge Storage in Inches  
(MCF 0.5 –1.5 & 4.5 are all 31 inches)

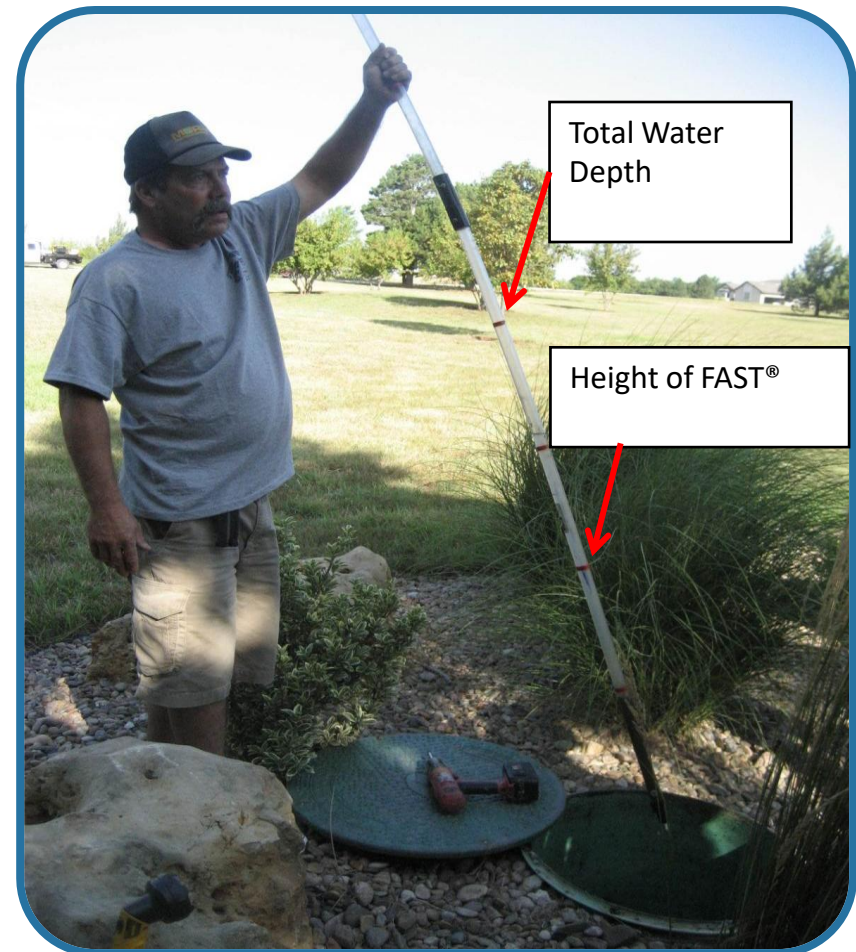

# Effluent Water Quality

## LOOK AT THE EFFLUENT QUALITY

- Effluent should be clear and odorless
- All FAST<sup>®</sup> systems are capable of exceeding the USEPA standard for secondary wastewater treatment depending on how they are applied, sized, installed, and operated.



# Field Equipment

## pH meter



## DO Meter





BETTER WATER. BETTER WORLD.®

8450 Cole Parkway • Shawnee, KS 66227 • Phone: 913-422-0707 • Fax: 913-422-0808

E-mail: onsite@biomicrobics.com • www.biomicrobics.com • 800-753-FAST (3278)

### FAST®, STAAR® & BioBarrier® MAINTENANCE INSPECTION AGREEMENT

*For Bio-Microbics, Inc. Authorized Technician*

It is hereby agreed this \_\_\_\_ day of \_\_\_\_\_, \_\_\_\_\_ (year) by and between \_\_\_\_\_ (owner) and \_\_\_\_\_ of \_\_\_\_\_ (service provider) that in consideration of the payments provided for herein, \_\_\_\_\_ will provide the services of a factory-trained representative to perform a Preventative Maintenance Inspection of the equipment described herein on the frequency shown below.

Each inspection of the equipment shall be followed by a written report to the Purchaser. The inspection report will describe the operational status of the system. It will also include recommendations for any preventative maintenance deemed necessary by the inspector as well as a list of any replacement parts needed.

This agreement does not assume any responsibilities or obligations which are normally the responsibilities of Purchaser's maintenance department (if applicable) as related to parts or labor and does not extend to cover any costs that may be associated with any recommendations made under this agreement.

\_\_\_\_\_ can only supply parts or labor after receipt of Purchaser's purchase order. Billings for inspection trips shall be made on a \_\_\_\_\_ basis.

In no event shall Bio-Microbics, Inc. or \_\_\_\_\_ be responsible for special or consequential damages, including but not limited to, loss of time, injury to person or property or any other consequential damages or incidental or economic loss due to equipment failure or for any other reason whatsoever.

This agreement shall remain in force for a period of \_\_\_\_ year(s), beginning \_\_\_\_\_, \_\_\_\_\_ (year) and ending \_\_\_\_\_, \_\_\_\_\_ (year).

#### Equipment Covered Under This Agreement

Nomenclature	Serial Number	Location	Min No. of Annual Trips	Annual Rate

**Purchaser:**  
 Sign: \_\_\_\_\_  
 Print: \_\_\_\_\_  
 Date: \_\_\_\_\_  
 Address: \_\_\_\_\_  
 Address: \_\_\_\_\_  
 Phone: \_\_\_\_\_  
 Fax: \_\_\_\_\_  
 E-mail: \_\_\_\_\_

**Service Provider:**  
 Sign: \_\_\_\_\_  
 Print: \_\_\_\_\_  
 Date: \_\_\_\_\_  
 Address: \_\_\_\_\_  
 Address: \_\_\_\_\_  
 Phone: \_\_\_\_\_  
 Fax: \_\_\_\_\_  
 E-mail: \_\_\_\_\_



BETTER WATER. BETTER WORLD.®



## NOTICE TO OCCUPANT

The wastewater that is produced by your residence or business is treated by FAST®, an advanced wastewater treatment system. The FAST® treatment unit is located on your property and is an on-site treatment system. Any on-site treatment and disposal system will work properly provided the occupants of the premises do not place harmful substances in the system. Therefore, certain standards must be followed in order to receive optimal performance from your FAST® system. You may be interested to know that most of these same standards are also important to follow even for those who are connected to a municipal or city sewer treatment system or conventional septic systems. Please refer to the list below for important information on how to help keep your treatment system performing as it should. In addition to these standards, all required maintenance must be completed in a timely manner.

**DO NOT SHUT THE BLOWER OFF** (Notify your maintenance provider if it appears to be functioning improperly or if you will be leaving the property for an extended period of time.)

### **DISINFECTANTS OR BLEACHES**

Use in accordance with manufacturers recommendations and sparingly. Quaternary ammonia sanitizers (found primarily in commercial settings) or pine oil cleaners should not be used.

### **MEDICATIONS**

Normal use of over the counter medications should not affect the system. However, strong antibiotics or chemotherapy drugs have been known to severely disrupt the treatment process. Please notify your service provider of this kind of issue so they may be aware of the reason for the system upset.

### **DETERGENTS**

Should be low-suds, biodegradable, and low phosphate. (Some examples are: Arm & Hammer, ALL, and Ecolab® Products (commercial use))

### **PAPER PRODUCTS**

Use white toilet paper products. Some natural bacteria do not eat color dyes in paper and therefore do not breakdown colored paper. Non-bleached paper (brown in color) takes a long time to breakdown due to the increased level of wood pulp.

**NO TOILET BOWL TABLETS SHOULD BE USED.**

**NO DISCHARGE FROM WATER SOFTENERS SHOULD GO INTO THE SYSTEM.**

**NO ANIMAL FATS, SUCH AS BACON GREASE, LARD, OR ANY OTHER OILS SHOULD GO INTO THE SYSTEM.** (Normal cleaning of pots and pans is acceptable).

**NO DRAIN CLEANERS SHOULD BE USED.** (Vinegar and baking soda mixed in the drain is a good substitute. As a last resort, chemical drain cleaners can be used, but use sparingly because they are toxic to the bacteria in the system.)

**NO LIQUID FABRIC SOFTENERS SHOULD BE USED.** (These products typically contain quaternary ammonia which is toxic to the bacteria. Please use dryer sheets.)

**NO HARSH CHEMICALS OR TOXINS SHOULD BE PUT INTO THE SYSTEM**  
(i.e. Floor stripping waste / household paints / solvents / thinners / caustic cleaners / pesticides / herbicides etc.)

### **OBJECTS NOT TO BE PUT INTO THE SYSTEM**

DISPOSABLE DIAPERS	CAT LITTER	SANITARY NAPKINS
BANDAGES	CIGARETTE BUTTS	AUTOMOTIVE FLUIDS
RAGS	STRING	STICKS
MUD	CONDOMS	PLASTICS
METAL OBJECTS	PAPER TOWELS	CORN COBS
ANIMAL BONES	MELON RINDS	COFFEE GROUNDS
HOME BREWERY WASTE	EGG SHELLS	OLD MEDICATIONS

### **Laundry Wash Loading**

It is recommended that wash loads be spread throughout the week.

### **Septic Tank Additives, Enzymes, and Bacteria**

Under normal circumstances these would be unnecessary with advanced treatment systems and not recommended for traditional septic systems.



## Property Sizing Survey

Name: \_\_\_\_\_

Address: \_\_\_\_\_

City, State, Zip: \_\_\_\_\_

How often do you spend time at this location?

- Full-time all year long
- Full-time for part of the year - Please specify what months: \_\_\_\_\_
- Weekends only – year round
- Weekends only – for part of the year – Please specify what months: \_\_\_\_\_

How many people occupy this location fulltime?

- 1-2
- 3-4
- 5 or more

 Occupant Medications/Antibiotics: Type/Quantity: \_\_\_\_\_

How many bedrooms are located within the dwelling?

- 1
- 2
- 3
- 4 or more

Please check all cleaning supplies used in the home on a regular basis:

- bleach: uses and quantity/week: \_\_\_\_\_
- liquid fabric softeners: quantity/week: \_\_\_\_\_
- toilet tablets
- ammonia cleaners: uses and quantity/week: \_\_\_\_\_
- Anti-bacterial cleaning agents: brand name, uses and quantity/week:  
\_\_\_\_\_  
\_\_\_\_\_

 drain cleaners: uses and quantity/week: \_\_\_\_\_

Please check your water source:

- private well
- public supply
- unsure

If you are on a private well – is your well chlorinated? \_\_\_\_\_

Do you have a water softener? \_\_\_\_\_  
Does it discharge into the septic system? \_\_\_\_\_

Owners Signature: \_\_\_\_\_ Date: \_\_\_\_\_

8450 Cole Parkway ▪ Shawnee, KS 66227 ▪ Phone: 913-422-0707 ▪ Fax: 913-422-0808

E-mail: onsite@biomicrobics.com ▪ www.biomicrobics.com ▪ 800-753-FAST (3278)





8450 Cole Parkway • Shawnee, KS 66227 • Phone: 913-422-0707 • Fax: 913-422-0808  
 e-mail: onsite@biomicrobics.com • www.biomicrobics.com • 800-753-FAST (3278)

## FIELD INSPECTION & SERVICE REPORT

### MicroFAST® Wastewater Treatment Systems

INSTALLATION			AUTHORIZED SERVICE PROVIDER	
Installation Address:			Name:	
Owner Name:			Street:	
Mail Address:			Mail Address:	
City	State	Zip	City	State Zip
Phone	Fax		Phone	Fax
e-mail			e-mail	
INSTALLATION INFORMATION				
Model No.	Blower Brand and Size	Serial No.	Date of Installation	Date of last pump-out
EQUIPMENT OPERATION	YES	NO	DETAILED COMMENTS OF SITE CONDITIONS – MAINTENANCE PERFORMED OR REQUIRED	
<b>Electrical Panel(s)</b>				
Visual Alarm Operating				
Audio Alarm Operating (if present)				
<b>Blower(s):</b>				
Air Inlet Filter Clean				
Blower Hood Vents Clear				
Excessive Noise				
Excessive Vibration				
<b>Treatment Unit(s):</b>				
Unusual Odor				
<b>System Vent</b>				
<b>Pumpout Required:</b>				
Primary Settling Zone				
Aerobic Treatment Zone				
EFFLUENT:	LIMIT	RESULT		
Estimated Daily Flow				
pH (Standard Units)	6-9 S.U.			
Color	Clear			
Temperature				
Dissolved Oxygen (effluent)	2 mg/L			
Odor	Slightly Musty odor (not septic)			
OWNER SIGNATURE		TECHNICIAN SIGNATURE		SERVICE DATE



BETTER WATER. BETTER WORLD.®





# Questions